

SN74LS11N

Product Introduction

The SN74LS11N is a digital integrated circuit that integrates three sets of three input and AND gates.

Product Features

- Integrating three sets of three INPUT AND gates
- Fully compatible with TTL/DTL input and output logic level
- Package : DIP14, SOP14

Product Applications

- Digital logic driver
- Industrial control applications
- Other application areas Battery-powered equipment

Package and Pin Assignment

SOP14 or DIP14.			
Pin NO	Pin Definition	Pin NO	Pin Definition
1	Input A1	14	Supply VCC
2	Input B1	13	Input C1
3	Input A2	12	Output Y1
4	Input B2	11	Input C3
5	Input C2	10	Input B3
6	Output Y2	9	Input A3
7	Supply GND	8	Output Y3

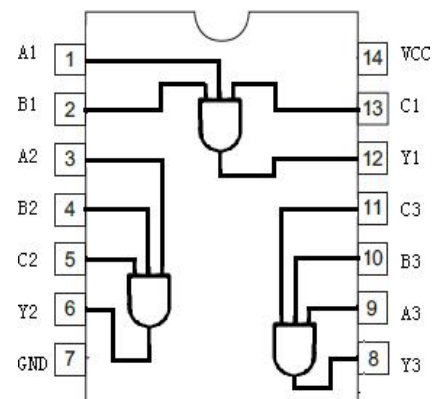

Absolute Maximum Ratings

Item	Symbol	Maximum Ratings	Unit
Supply voltage	V_{CC}	7	V
Input voltage	V_I	7	V
Power dissipation	P_D	500	mW
Operating temperature	T_A	0-70	°C
Storage temperature	T_S	-65-150	°C
welding temperature	T_W	260	°C, 10s

Note: the limit parameter is the limit value that cannot be exceeded under any condition. Once this limit is exceeded, it may cause physical damage such as deterioration of the product. At the same time, the chip can not be guaranteed to work properly when it is close to the limit parameters.

■ Block Diagram

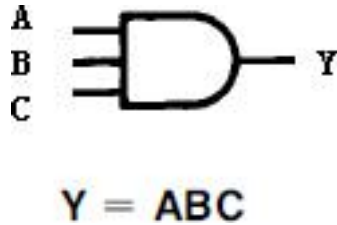

■ Function Table

Inputs			Output
A	B	C	Y
X	X	L	L
X	L	X	L
L	X	X	L
H	H	H	H

H = High Logic Level
 L = Low Logic Level
 X = Either Low or High Logic Level

■ Recommended Operating Conditions

Item	Symbol	Min	Tpy	Max	Unit
Supply voltage	V_{CC}	4.75	5	5.25	V
Input voltage	V_{IH}	2	—	—	V
	V_{IL}	—	—	0.7	V
Output current	I_{OH}	—	—	-400	uA
	I_{OL}	—	—	8	mA
Operating temperature	T_A	0	—	60	°C

■ Electrical Characteristics

($T_A=25^\circ\text{C}$, Unless specified)

Item	Symbol	Min	Tpy	Max	Unit	Conditions	
Output voltage	V_{OH}	2.7	3.7	—	V	$I_{OH}=-400\mu\text{A}$	$V_{CC}=4.75\text{V}, V_{IH}=2\text{V}$
	V_{OL}	—	0.20	0.4	V	$I_{OL}=4\text{mA}$	$V_{CC}=4.75\text{V}, V_{IL}=0.7\text{V}$
		—	0.33	0.7		$I_{OL}=8\text{mA}$	
Input current	I_I	—	0.4	20	uA	$V_{CC}=5.25\text{V}, V_I=7\text{V}$	
	I_{IH}	—	0.0	20	uA	$V_{CC}=5.25\text{V}, V_I=2.7\text{V}$	
	I_{IL}	—	0.25	0.4	mA	$V_{CC}=5.25\text{V}, V_I=0.4\text{V}$	
Short-circuit output current	$I_{OS}(\text{Note1})$	—	-15	-100	mA	$V_{CC}=5.25\text{V}$	
Supply current	I_{CCH}	—	1.9	3.6	mA	$V_{CC}=5.25\text{V}, \text{all } V_I=V_{CC}$	
	I_{CCL}	—	4.2	6.6	mA	$V_{CC}=5.25\text{V}, \text{all } V_I=\text{GND}$	
Input clamp voltage	V_{IK}	—	0.9	-1.5	V	$V_{CC}=4.75\text{V}, I_I = -18\text{mA}$	

Note1: only one output port is short circuited each time, and the short circuit time is not more than one second.

■ Switching Characteristics

($T_A=25^\circ\text{C}$, Unless specified)

Item	Symbol	Min	Tpy	Max	Unit	Conditions
Propagation delay time	t_{PLH}	—	40	—	ns	$V_{CC}=5\text{V}, C_L=16\text{pF}, R_L=2\text{K}\Omega$
	t_{PHL}	—	14	—	ns	

■ Testing Method

1、Test Circuit

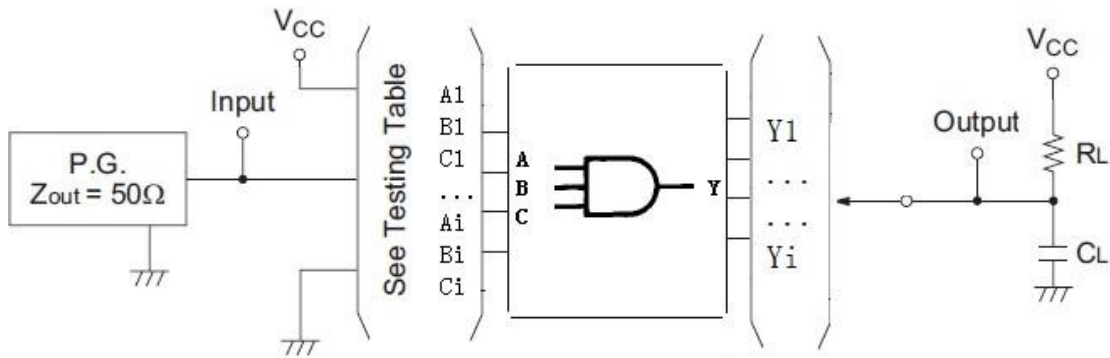

2、Waveform

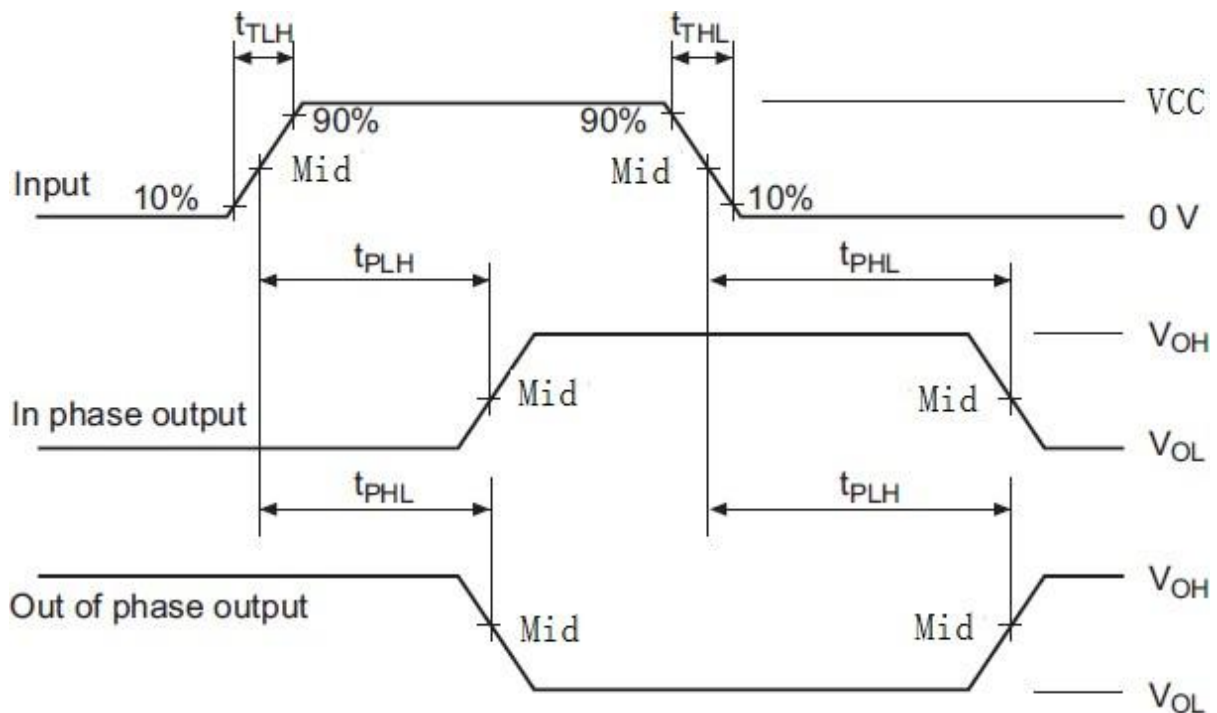

Note:

1. See Testing Table refers to the corresponding test items in the switch characteristic table.
2. the CL capacitor is an external patch capacitor (0603), which is connected to the output pin and the capacitor is near the chip GND.
3. Input: port input level, $f=500\text{kHz}$, $D=50\%$, $t_{TLH}=t_{THL}$ or less 20ns;
4. Output: Y output test port (Out of Phase Output, In Phase Output)

■ Package Dimensions

Unit : mm /inch

DIP14

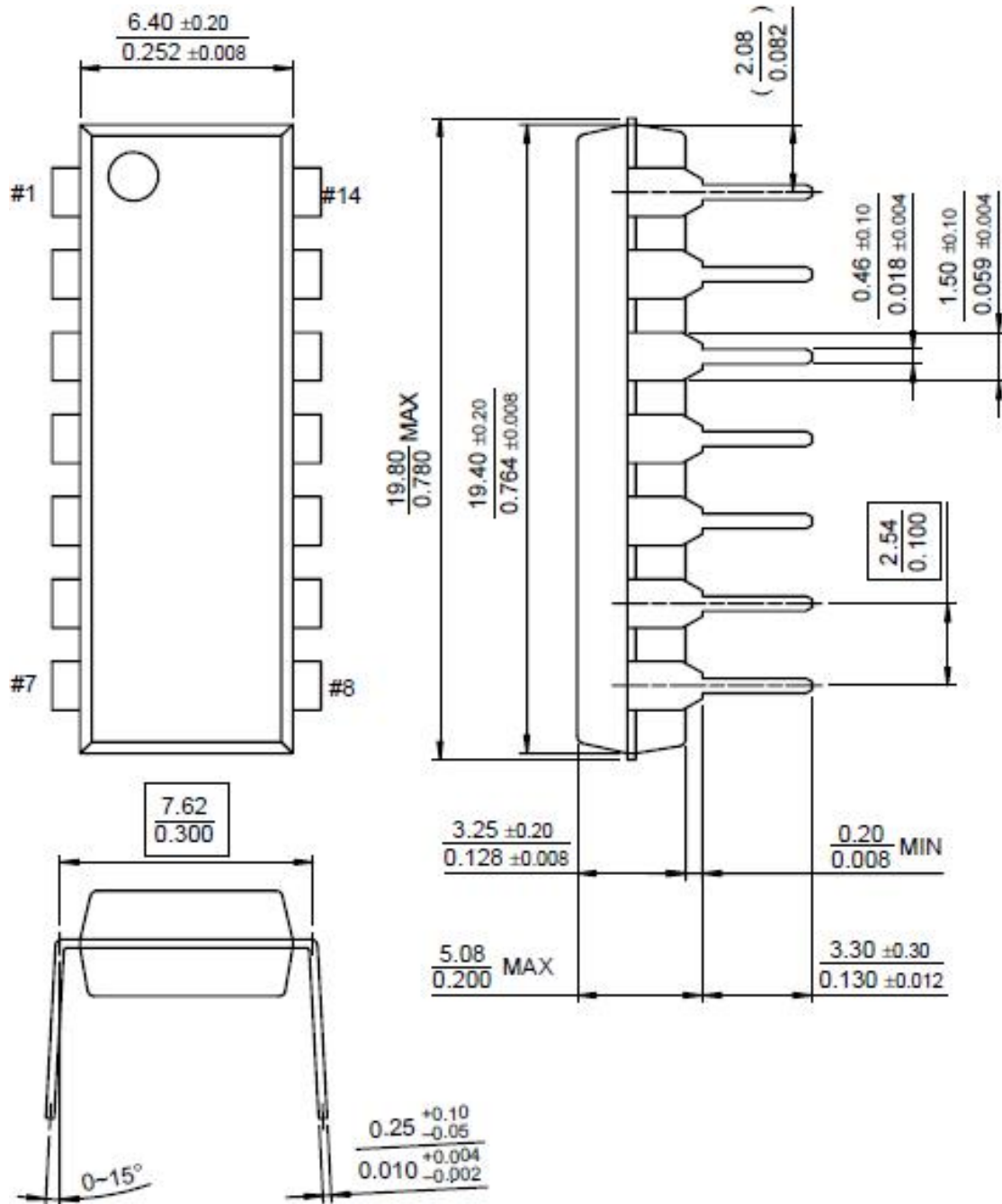

SOP14

