

Features

- Contact switching capability is 20A 14VDC
- Contact arrangement: 1A、1C
- Standard PCB terminal
- Plastic sealed, Flux proofed
- Small size, light weight
- UL insulation system: Class F
- Environment-friendly product (RoHS compliant)
- Outline Dimensions: (15.5×12.0×13.7) mm
- Main application: Automobile door lock、Automatic doors and Windows、Turn light

CHARACTERISTICS

Specifications	Item		
Contact Data	Contact arrangement		1A、1C
	Contact resistance(initial)		≤100mΩ(6VDC 1A)
	Contact material		AgSnO ₂
Rated value	Rated load(Resistance load)		20A 14VDC 5A 250VAC
	Max.switching voltage		250VAC/16VDC
	Max.switching current		20A
	Max.switching capacity		1250VA/280W
	Min.allowing load		5VDC 100mA
Electrical performance	Insulation resistance(initial)		1000MΩ(500VDC)
	Dielectric strength (initial)	Between open contacts	750VAC,1min
		Between coil&contacts	750VAC,1min
	Operate time		≤10ms
	Release time		≤5ms
Mechanical performance	Shock resistance	Functional	98m/s ² (10g)
		Destructive	980m/s ² (100g)
	Vibration resistance		10Hz~55Hz 1.5mm DA
Endurance	Mechanical		1×10 ⁷ ops
	Electrical		20A 14VDC 1×10 ⁵ ops (ON/OFF=1s/9s) 5A 250VAC 1×10 ⁵ ops (ON/OFF=1s/9s)
Operate condition	Ambient temperature		-40℃~85℃
	Humidity		5% to 90%
Termination			PCB
Unit weight			Approx.6g
Construction			Plastic sealed、Flux proofed

■ COIL DATA(23℃)

■ Standard Type

Nominal Voltage	Pick-up Voltage VDC	Drop-out Voltage VDC	Rated Current (± 10%)	Coil Resistance (± 10%)	Nominal Power	Max Voltage
DC 5V	≤3.75	≥0.25	120mA	41.7Ω	600mW	DC 6.5V
DC 6V	≤4.50	≥0.30	100mA	60Ω		DC 7.8V
DC 9V	≤6.75	≥0.45	66.7mA	135Ω		DC 11.7V
DC 12V	≤9.00	≥0.60	50mA	240Ω		DC 15.6V
DC 15V	≤11.25	≥0.75	40mA	375Ω		DC 19.5V
DC 18V	≤13.50	≥0.90	33.3mA	540Ω		DC 23.4V
DC 24V	≤18.00	≥1.20	25mA	960Ω		DC 31.2V

■ Sensitive Type

Nominal Voltage	Pick-up Voltage VDC	Drop-out Voltage VDC	Rated Current (± 10%)	Coil Resistance (± 10%)	Nominal Power	Max Voltage
DC 3V	≤3.75	≥0.25	72mA	69.4Ω	360mW	DC 6.5V
DC 5V	≤4.50	≥0.30	60mA	100Ω		DC 7.8V
DC 6V	≤6.75	≥0.45	40mA	225Ω		DC 11.7V
DC 9V	≤9.00	≥0.60	30mA	400Ω		DC 15.6V
DC 12V	≤11.25	≥0.75	24mA	625Ω		DC 19.5V
DC 15V	≤13.50	≥0.90	20mA	900Ω		DC 23.4V
DC 18V	≤18.00	≥1.20	15mA	1600Ω		DC 31.2V

■ ORDERING INFORMATION

	FH28	-1A	S	T	L	-XXX	DC5V
① Type							
② Contact arrangement: 1A=1open contacts, 1C=1 switched contacts							
③ switched contacts(1): Nil=Flux proofed, S=Plastic sealed							
④ Contact material: T=AgSnO ₂							
⑤ Coil power: Nil=Standard, L=Sensitive(type A only)							
⑥ Customer special code: numbers or letters denote customer's requirements							
⑦ Coil specification: DC3/5/6/9/12/15/18/24V							

- (1) When used in clean environment(excluding H₂S、SO₂、NO₂、dust and other pollutants), it is recommended to choose the Flux proofed type;When used in unclean environment(contain H₂S、SO₂、NO₂、dust and other pollutants), it is recommended to choose the Plastic sealed.

■ OUTLINE DIMENSIONS, WIRING DIAGRAM AND PC BOARD LAYOUT (Unit: mm)

1A Outline Dimensions

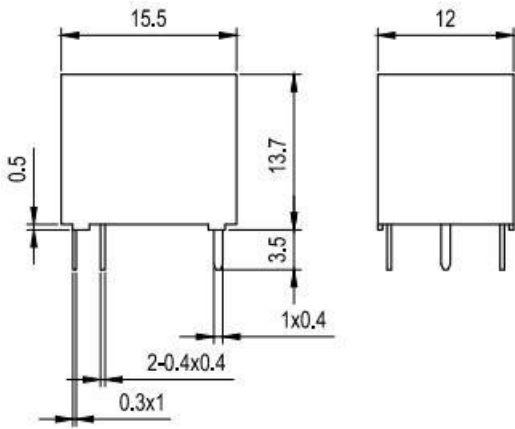

Wiring Diagram
(Bottom view)

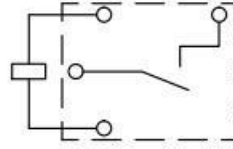

PCB Layout
(Bottom view)

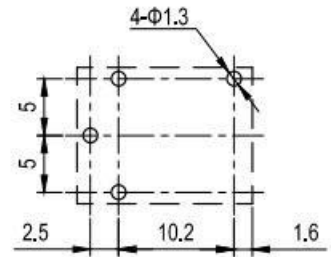

1C Outline Dimensions

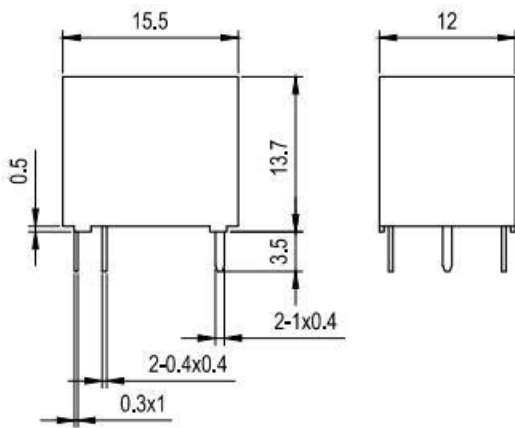

Wiring Diagram
(Bottom view)

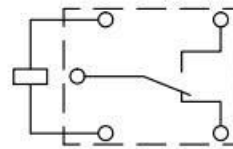

PCB Layout
(Bottom view)

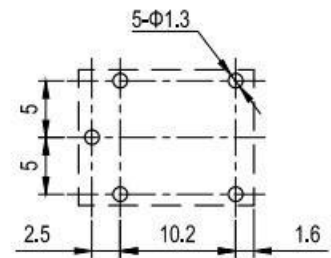

Remark:(1)In case of no tolerance shown in outline dimension:outline dimension \leq 1mm,tolerance should be \pm 0.2mm;outline dimension $>$ 1mm and $<$ 5mm,tolerance should be \pm 0.3mm;outline dimension \geq 5mm,tolerance should be \pm 0.5mm.

(2) The tolerance without indicating for PCB layout is always \pm 0.1mm.

■ PERFORMANCE CURVES

MAXIMUM SWITCHING POWER

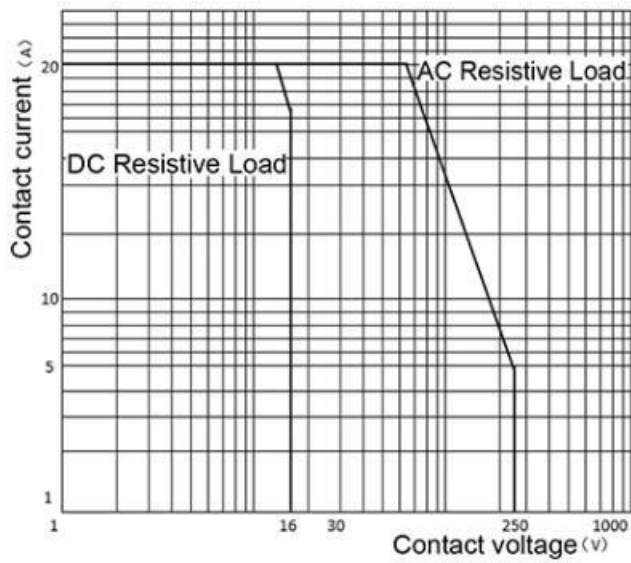

ENDURANCE CURVE

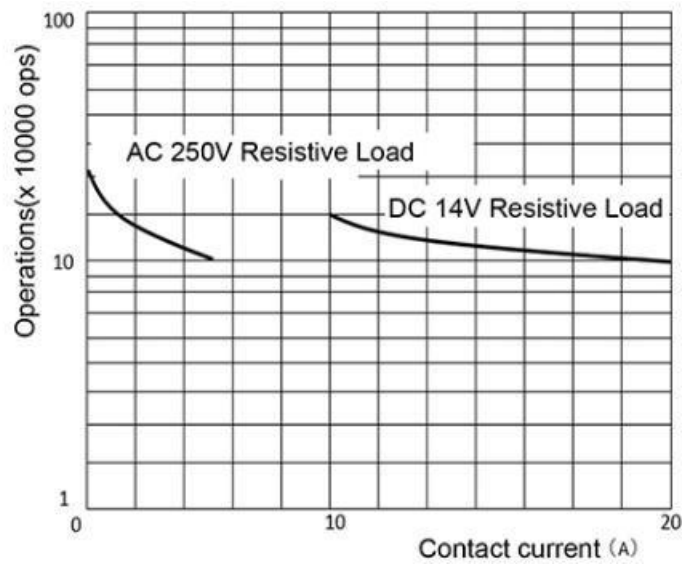

■ NOTICE

- ① In order to maintain the initial performance parameters of the relay, please be careful not to drop the product;
- ② The specification is for reference only. Specifications subject to change without notice.