

# DL24 Color Screen Bluetooth Data Transmission Digital control Curve Load Meter User manual

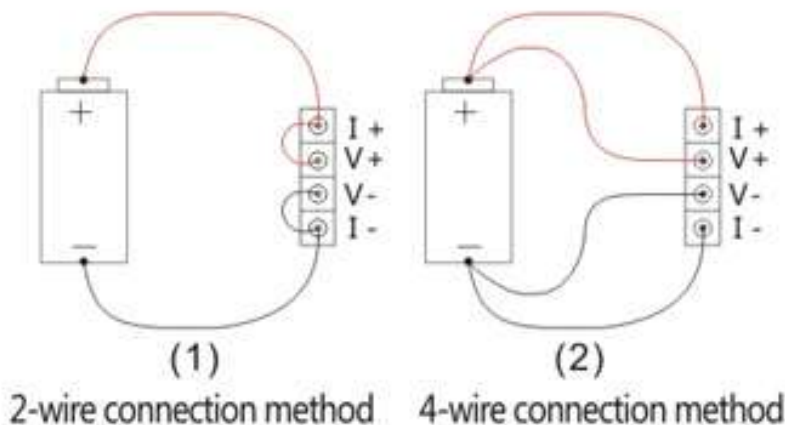

## Two input connection methods



(1) 2-wire wiring method: This method is relatively simple and convenient. I+ and V+ are shorted, I- and V- are shorted, the two holes are combined into one Connect to the I+ and I- terminals

(2) 4-wire connection method: voltage measurement is not affected by the voltage drop of the wire The influence of voltage measurement is more accurate. It is recommended to have a certain circuit base Basic users use this method

This product is used to inspect and test the capacity of various batteries , discharge and aging various power adapters, USB chargers, various mobile power and other power supply equipment

Product line arrangement for technology constantly updated and keys function with minor discrepancy adjustment and manual without prior notice, in accordance with the purchase details page introduction



# Introduction and parameters of interface and key functions

Product the power supply input port  
(12V/1A)

Bluetooth icon

(Mobile phone or computer bluetooth connection successful digital display blue, not connected show gray)

Constant current, constant resistance and constant power, constant voltage mode

Preset discharge value

DC5.5 Test inputs  
MiNi USB Test inputs  
Micro USB Test inputs  
Type-C Test inputs

Outer NTC temperature probe socket



## Electrical parameters

Test voltage : 2~200V  
Working current : 0.2~20A  
DL24 Discharge power: voltage \* current < 150 W  
DL24P Discharge power: voltage \* current < 180 W  
(The actual running current is limited by the maximum power, please adjust the current according to the law of energy conservation)

The built-in over-current, over-temperature, over-power safety protection functions, if the protection interface is popped up, please pay attention to the parameter adjustment, shall adjust to the maximum power, and then discharge, you can first slowly and smoothly adjust the preset value in the start and discharge, in order to adjust up to the maximum power for discharging

Output to the standard of instrument calibration constant current load

Bluetooth ANT

System sound speakers

Computer APP PC online interface

Setup button  
(Short press the cursor to move, long press to enter the mode and value setting)

+/- button

Built-in discharge tube temperature display

Start button  
(Short press to start and stop, long press to enter the system background settings)

Warning: the default constant current value in the discharge process zhongheng flow using automatic tuning technology, constant current GenJin measurements with a tail beat after the decimal point belongs to the normal phenomenon

## Fast application method of constant current discharge mode:

Insert the power supply adapter inside the packing box into the power input port of product end, at this time the product is lit up, and then after the power supply under test is connected, the display screen shows the present measured values of the input voltage, short press the set key at this time, the cursor below the constant current digital move the cursor around, again through the short press add or subtract keys, after the corresponding numerical is adjusted to the current value that you need the discharge, again press the start key, the display screen shows "ON", begin the constant current discharge, battery capacity accumulation, and timing; If you need to set a time-limit discharge time and the stop voltage value, please, when the stop of discharging, long press the set key one time, the CC of display interface begin the beating show, then short press set key, moves to the numerical



flicker of limit-time discharge column, the beating numerical can be adjusted by short pressing the plus or minus keys, after setting a short press start key, save and confirm or wait the stop of flicking, automatically save.

## **Application methods of constant resistance, constant power and constant voltage**

Under the state of the product electricity and stop discharge, long press the set key, the CC of display interface begin the beating show, at this time, again short push the add or subtract key, adjustment a few model of CR - CP - CV – CC for cycling the show, after selecting the corresponding function model, and after waiting for the stop of flickering, the system saves and enters into this function model, and then can adjust and open, close, discharge by using the same application methods of constant current discharge model in the above section.

## **Methods and techniques for the inspecting and measuring of battery capacity and electric quantity**

Firstly, Your battery to be measured is fully charged, and then long press the start key of this product to enter the backstage, the accumulated data is reset, and exit the backstage, long press the set key CC again, start flickering, short press the set key to the stop voltage column, after setting your lowest voltage of battery discharge, short press the start key to save, and then set the rated current value of discharge well, short press the start key to start measuring the accumulated capacity value of battery, when the discharge aging is up to the stop voltage value of battery that you set, the system will display a "Complete!" ", indicating that the capacity measuring and testing is completed, at this point, the capacity mAH and power Wh showed on the display screen is the capacity and power value of battery.

## **Detection methods and techniques for the output voltage and current value and maximum power value of DC power adapter**

Connect the output of your power supply to the product, the display screen displays the current voltage value, and then set the nominal current value of the power supply to be tested to this device, and then start the load for 3-6 hours discharge aging. During the process, the temperature of the power supply to be tested is not high and the voltage is stable, indicating that the quality of the power supply under testing is stable, and the



nominal value is accurate without any false marking; in the process of starting "ON" to discharge, by short pressing the +/- key, the current is increased to the moment when the voltage of the power supply under test drops and the voltage is zero, read the current value and power value, this is the maximum output current value and output maximum power value of the power supply under test.

## Testing methods and techniques for capacity and electricity quantity of mobile power supply

First, charge your charge pal fully, and then the load capacity and electricity quantity are reset, begin to access this load and set discharge value well, began to discharge until the charge pal runs out, at this time, read the cumulative capacity and power value above the display screen, this is the approximate values for the capacity and electricity quantity of charge pal, treasure because this product inside has the power-off memory function, the discharge can be completed in one time, the discharge process can also divided into the many-times discharge, check the capacity value again until the power of charge pal runs out.

The operation method for one key clear-zero of data: long press the start key, after entering the background, and then short press the setting key to change color and move to the data clear-zero column, and then short press the start key to pop up "OK!"The word indicates that all data is cleared.

Kindly remind: Because the nominal capacity value marked by the charge pal on market at present is mostly the batteries value inside the machine, and thus from the 3.7 V batteries are increased to 5 V or 9 V and other physical capacity difference of voltage, and the voltage loss is produced during the process of voltage rise, so that the above 5 V voltage is tested, the electric capacity value is far less than the nominal value, according to the experience, according to the assessment of current mainstream brands mobile power, the total loss for the loss of voltage rising plate plus the difference of voltage rise is about 35%, so the true and false of nominal value for the charge pal need to be tested, take the boosting to 5V output voltage as an example, the measured capacity value needs to be multiplied by about 1.35, which is approximately equal to the nominal value of the charge pal itself, this evaluation value can only be taken as the relative value but not as the absolute value.

## Testing the rated current value and quality of the charging cable and data cable

Connect as shown in the following figure, when the load is applied, short press +/-, When the voltage drop is 1V less than the no-load voltage, the current value at this point is the current value of the cable line under test.



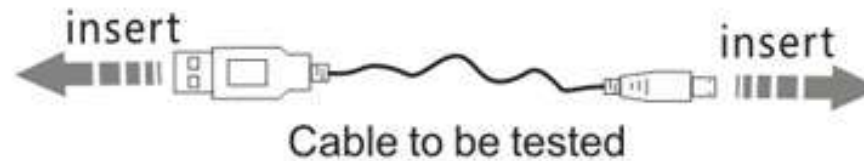
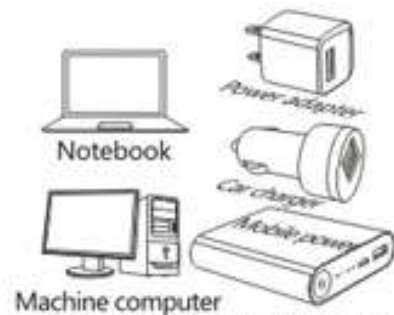

Cable to be tested

Figure 1



(Power supply output current value measured data line current value must be selected is greater than the power supply, can normal test)

## Testing the maximum output current method of the charger and its quality

Connect according to Figure 1, the constant current of the load during discharge is changed to make the voltage drop sharply or the voltage abrupt change to zero. At this time, the current value is the maximum current value that can be output by the charger; again change the load to the nominal current value of charger for the discharge aged 2 ~ 6 hours, the current voltage is stable in the process of aging, the temperature of the charger is also less than 50 degrees or so, indicating the nominal current of this charger conforms to reality with no virtual marking, the charging speed can be satisfied, on the contrary, if the voltage is reduced, the current value difference is too big or the temperature is too high, even U meter alarm to flicker, and there is no output, these belong to the current virtual marking, there is a sign of poor quality, this method is also suitable for the output current test judgment method of all the USB interface.

## The download and installation of the online mobile APP and computer APP

Android mobile phone: after scanning the code and entering the link to download and install, and then open the APP, click the bluetooth icon in the upper left corner of the interface, select the model DL24 to connect, return to the APP interface, this time the bluetooth icon changes from grey to blue, indicating the connection and communication are successful; the Apple mobile phone can be downloaded, installed and used in the application search E\_test

(Warning: If the bluetooth device model corresponding to J cannot be found in the APP of the electric energy meter, please be sure to open the storage permissions and location information of the device APP in the settings of the mobile phone!)

Please be in accordance with the online and use instructions of electronic version under the download directory for the download application in PC computer APP.