

电路简图
SCHEMATIC

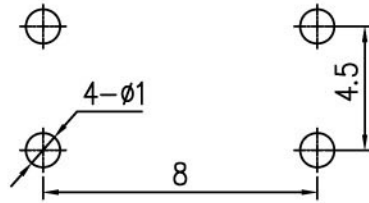

印制线路板
Recommended P.C.B layout

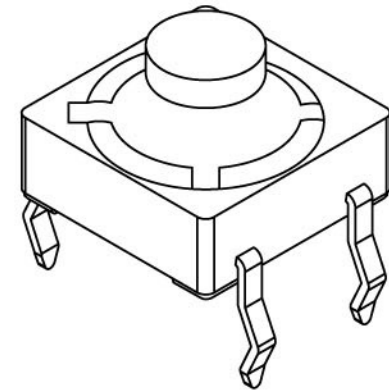

1. Rating: DC12V 50mA.
2. Operating Force: 120±40gf.
3. Contact Resistance: 200ΩMax.
4. Life: 50,000 Cycles Min.

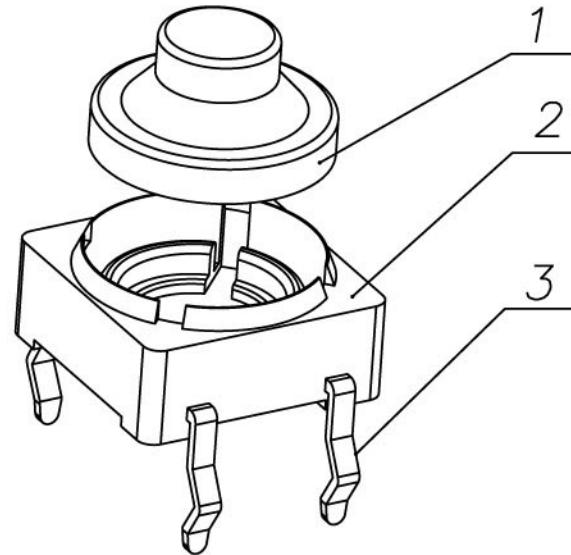
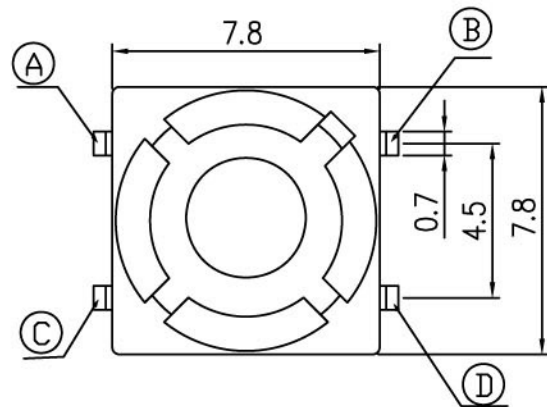

3	嵌件	黄铜	—	镀银
2	基座	PA66	黑色	清洗
1	帽头	硅胶	灰色	外购
序号 NO.	名称 DESCRIPTION	材料 MATERIAL	颜色 COLOR	备注 REMARK

工程变更通知单 ECN(DCN) NO.	版次 REV	日期 DATE	说明 DESCRIPTION	改变 CHANGE	承认 APPRO.	Angle 30~ 10~30 ~10	±2' ±0.3 ±0.2 ±0.15	DESIGN CHECK VERIFY APPROVAL	设计 校对 审核 批准	品名 ITEM NO.	8*8*5.5轻触开关				
						未注公差 GENERAL TOLERANCE UNLESS OTHERWISE NOTED				料号 PART NO.	TSX8855S-120AH				
										图号 DRAWING NO.	B 状态码	3.608.130			
										SCALE		UNIT	mm	A4	☉