

Overview

The industry leading HP R/T3000 G2 Uninterruptible Power System (UPS) packs up to 3000 watts into a space saving 2U design. Proven Digital Signal Processor (DSP) double conversion system provides clean, reliable power protection in an energy efficient transformer-less design while reducing generated heat.

The HP R/T3000 G2 UPS includes a Rack to Tower Conversion Kit for non rack applications outside the data center. In this configuration the HP R/T3000 G2 can provide powerful protection to multiple tower servers as well as tower Blade Enclosures such as the HP BladeSystem c3000 Enclosure.

In addition, Extended Runtime Modules (ERM) are available to increase battery run time during a power outage. ERMs can be used in both rack mount and tower configuration with the HP R/T3000 G2UPS.

Robust and Flexible UPS management is provided by HP's New Power Protector UPS Management software.

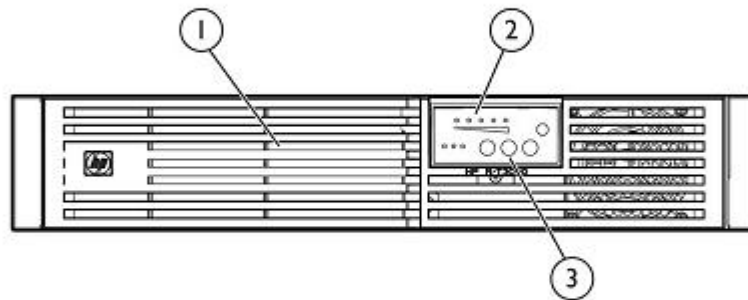

R/T3000 Rackmount UPS configuration

1. Front bezel - battery compartment behind bezel
2. Status LED indicators
3. Power control buttons

Overview

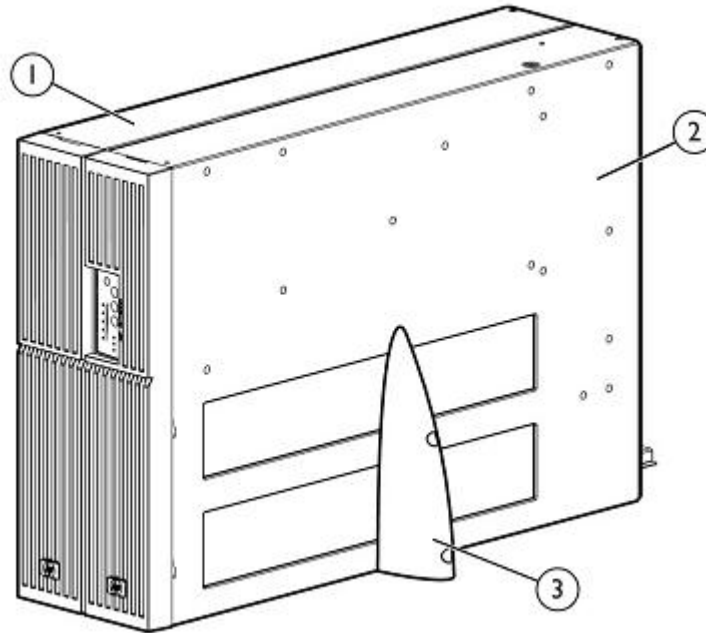

R/T3000 Tower UPS configuration with optional Extended Runtime Module

1. Optional Extended Runtime Module
2. R/T3000 in Tower UPS configuration
3. Tower UPS floor stands

Models

HP R/T3000 G2 2U L530 Low Voltage NA/JP Uninterruptible Power System	AF466A
HP R/T3000 G2 2U L620 High Voltage NA/JP Uninterruptible Power System	AF467A
HP R/T3000 G2 2U Detachable Cord High Voltage INTL Uninterruptible Power System	AF468A

Standard Features

Key Features

- New convertible design can be used as a 2U rack mountable UPS or as a standalone tower UPS
- Increased power density with up to 3300VA / 3000 Watts (200-240V models)
- Greater system uptime with support for up to two Extended Runtime Modules (ERM)
- Easy configuration through enhanced front panel display
- Enterprise-wide intelligent manageability with bundled power management software
- Support for the HP UPS Network Module that extends the power management capabilities of the UPS
- More efficient voltage regulation using digital signal processing technology
- Ultimate long-term battery reliability with HP Enhanced Battery Management
- Enhanced system flexibility with two independently controlled load segments
- Support for Remote Emergency Power Off (REPO) circuitry
- Easy serviceability through modular design
- Hot-Swappable Batteries
- Backed by a three year warranty with the first year including parts and labor. HP's Pre-Failure warranty, and a \$250,000 load protection guarantee*. (Certain restrictions and exclusions apply; *Load protection guarantee available in North America only.)
- Optional upgrades include:
 - Extended Runtime Modules (ERMs)
 - Management Cards

New Convertible Design The R/T3000 G2 can be used in a traditional rack mount environment or converted to a Tower UPS to support powerful Tower servers even Tower Blade Servers such as the HP c3000 BladeSystem.

2U Power Packed Design Rated near unity at 3300VA / 3000W (200-240V models), the HP UPS R/T3000 G2 packs more power in space-conserving rack-mount design, allowing you to support more critical equipment in your rack.

Increase System Uptime with Extended Runtime Modules The Extended Runtime Modules are external battery modules that occupy 2U (3.5 inches) of rack space each. The HP UPS R/T3000 G2 supports up to two Extended Runtime Modules (ERM), in either rack mount or tower configuration, which extend your overall battery runtime.

Lower Cost of Ownership with Innovative Technology The HP UPS R/T3000 G2 utilizes a new industry-leading technology that continually conditions and regulates power without using the battery, thereby increasing the life of the battery. The output voltage is automatically regulated, based on the connected load and the input voltage.

Investment Protection with HP Enhanced Battery Management HP UPS R/T3000 G2 incorporates Enhanced Battery Management: an exclusive, patented technology that doubles battery service life, optimizes battery recharge time, and provides advance notice of pending battery failure. With Enhanced Battery Management, you have a lower total cost of ownership and receive the best in the industry protection for your critical equipment.

Enhanced Flexibility The high voltage R/T3000 UPS include one PDU Extension Bar. The extension bar has seven C13 outlets for powering equipment in the rack and attaches to the C19 outlets on the back of the UPS. The 6.5 foot (2 meter) cord allows the extension bar to be mounted in many locations inside the rear of the rack.



Standard Features

Remotely Monitor UPSs on the Network The optional HP UPS UPS Module features the ability to perform simultaneous network and out-of-band communications. It enables network administrators to remotely monitor UPSs and reboot network devices. It provides SNMP functionality, including power event alerts, network power diagnostics, and remote UPS reboot and testing. Used in conjunction with HP Systems Insight Manager or other SNMP capable Network Management Software, power-related problems on the network are quickly discovered and remedied.

Enhanced Front Panel Display LED and switch membrane integrated into the front panel with power controls and status and load indicators for easy visibility.

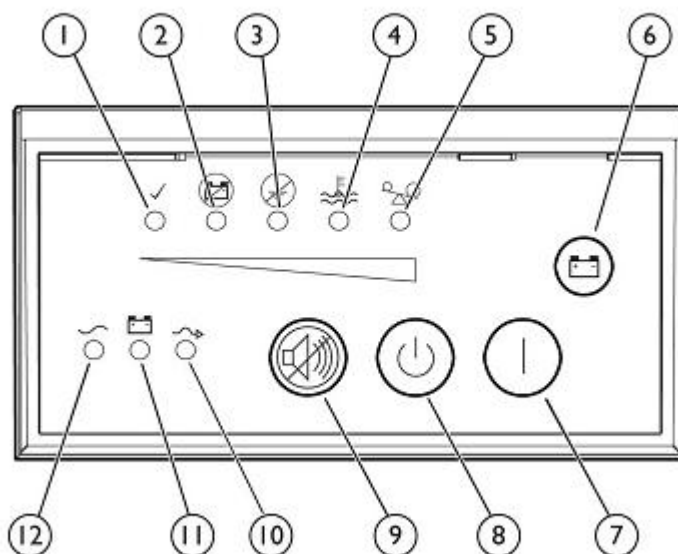

HP R/T3000 UPS Front Panel

- | | |
|---|-----------------------------|
| 1. Dual function LED: Self Test and load indicator (10% load) | 7. Power on button |
| 2. Dual function LED: Battery fault and Load Indicator (25% load) | 8. Power off button |
| 3. Dual function LED: Site wiring fault and load indicator (50% load) | 9. Test/Alarm reset button |
| 4. Dual function LED: Over Temperature and load indicator (75% load) | 10. On bypass indicator |
| 5. Dual function LED: Overload and load indicator (100%) | 11. On battery indicator |
| 6. Start on battery button | 12. Utility power indicator |

Standard Features

Intelligent Manageability HP Power Protector management software included with the R1500 G3 models. The HP Power Protector Software enables you to monitor and control an HP UPS locally or remotely. This software is a versatile, fully configurable, alert response tool that gives system administrators a full overview of the UPS's conditions. It enables you to monitor system status and power conditions, configure shut down timing, customize alert messages, and gracefully shut down servers during an extended power outage. For more information on HP Power Protector software please see: www.hp.com/go/hppp

Independently Controllable Load Segments With two independent controlled load segments, you have the flexibility to configure each segment's shut down schedule to maximize runtime for critical equipment.

Ease of Maintenance with Hot-Swappable Batteries The UPS R/T3000 G2 is designed with simple access through the front panel for hot swappable batteries. Users can safely install new batteries without ever powering down connected server and server options.

HP Quality HP's hardware qualification is the toughest in the industry. Extensive evaluation, testing, product improvement, and an unsurpassed warranty guarantee the highest level of system protection, electrical performance, product quality and compatibility.

Compatibility Compatible with all HP servers, storage, racks, rack options, and other rack mountable HP equipment (for PDU options please refer to the UPS/PDU compatibility matrix on <http://www.HP.com/ups>).

Warranty The HP UPS R/T3000 G2 is covered by a three year warranty, with the first year including parts and labor. Also, standard on all HP UPS units, is our exclusive Battery Pre-Failure Warning, which extends the advantage of a HP three-year, limited warranty by applying it to the battery before it actually fails. This warranty is offered worldwide. Specifically, the Battery Pre-Failure Warning ensures that when customers receive notification from HP Power Management Software that the battery may fail, the battery is replaced free of charge under the warranty.
NOTE: \$250,000 Computer/Load Protection Guarantee is also provided in North America, in addition to the HP three year, limited warranty.



Service and Support

Service and Support

HP Technology Services

HP Technology Services offers you consultants and support experts to solve your most complex infrastructure problems. We help keep your business running, boost availability and avoid downtime.

Protect your business beyond warranty with HP Care Pack Services

When you buy HP Options, it's also a good time to think about what level of service you may need. HP Care Pack services provide total care and support expertise with committed response choices designed to meet your IT and business need.

Recommended HP Care Pack Services for optimal satisfaction with your HP product

Recommended Services

3-Year HP 24x7 4 hour Response, Hardware Support Onsite Service

Provides you with rapid remote support and if required an HP authorized representative who will arrive on site any time and day of the year to begin hardware maintenance service within 4 hours of the service request being logged.

<http://h20195.www2.hp.com/V2/GetPDF.aspx/5982-6547EEE>

HP ProLiant Server Hardware Installation

Provides for the basic hardware installation of HP branded servers, storage devices and networking options to assist you in bringing your new hardware into operation in a timely and professional manner

<http://h20195.www2.hp.com/V2/GetPDF.aspx/5981-9356EN>

Related HP Care Pack Services to enhance your HP product experience

Related Services

3-Year HP 6 hour Hardware Support Onsite Call-to-Repair Service

Provides an IT manager with a team of support specialists who will quickly begin troubleshooting the system to help return the hardware to operating condition within 6 hours of the initial service request to the HP Global Solution Center

<http://h20195.www2.hp.com/V2/GetPDF.aspx/5981-6636ENN>

HP Proactive Select Service

Provides a flexible way to purchase HP best-in-class consultancy and technical services. You can buy Proactive Select Service Credits when you purchase your hardware and then use the credits over the next 12 months. <http://h20195.www2.hp.com/V2/GetPDF.aspx/4AA2-3842ENN>

Insight Remote

Support Delivers secure remote monitoring and support for HP servers and storage, 24x7 at no additional cost. Available as part of HP Warranty, Care Pack and Service Contract offers.

Parts and materials

HP will provide HP-supported replacement parts and materials necessary to maintain the covered hardware product in operating condition, including parts and materials for available and recommended engineering improvements. Supplies and consumable parts will not be provided as part of this service; standard warranty terms and conditions apply. Parts and components that have exceeded their maximum supported lifetime and/or the maximum usage limitations as set forth in the manufacturer's operating manual or the technical product data sheet will not be provided, repaired or replaced as part of this service.

Coverage

For ProLiant servers and storage systems, this service covers HP-branded hardware options qualified for the server, purchased at the same time or afterward, internal to the enclosure, as well as external monitors up to 22" and tower UPS products; these items will be covered at the same service level and for the same coverage period as the server unless the maximum supported lifetime and/or the maximum usage limitation has been exceeded. Coverage of the UPS battery is not included; standard warranty



Service and Support

terms and conditions apply.

The defective media retention service feature option applies only to Disk or eligible SSD/Flash Drives replaced by HP due to malfunction. It does not apply to any exchange of Disk or SSD/Flash Drives that have not failed. SSD/Flash Drives that are specified by HP as consumable parts and/or that have exceeded maximum supported lifetime and/or the maximum usage limit as set forth in the manufacturer's operating manual or the technical data sheet are not eligible for the defective media retention service feature option.

For more information

To learn more on services for HP ESSN Options, please contact your HP sales representative or HP Authorized Channel Partner. Or visit: <http://www.hp.com/services/proliant> or www.hp.com/services/bladestem



Innovative Options to Meet Your Data Center Needs

Optional UPS Network Module

The HP UPS Network Module enables you to monitor and manage power environments through comprehensive control of HP UPSs. The HP UPS Management Module can support either a single UPS configuration or provide additional power protection with support for dual redundant UPS configuration for no-single-point-of-failure. The additional serial ports will provide greater power management control and flexible monitoring.

The management module can be configured to send alert traps to HP Systems Insight Manager and other SNMP management programs or used as a standalone management system. This flexibility enables you to monitor and manage UPSs through the network. To facilitate day-to-day maintenance tasks, the embedded management software provides detailed system logs.

The HP UPS Network Module provides remote management of a UPS by connecting the UPS directly to the network. Configuration & Management of the UPS from anywhere and at anytime via a standard web browser.

NOTE: For more information on the UPS Network Module please see: www.hp.com/go/hpunm.

Extended Runtime Module (ERM)

The UPS R/T3000 G2 supports up to two Extended Runtime Modules. Each module is a 2U (3.5 inches), rack mountable battery module that extends your overall battery runtime.

Rack to Tower Conversion Kit

The included HP R/T3000 G2 UPS Tower Conversion Kit allows you to use the powerful R/T3000 G2 in a tower configuration for your most powerful tower Servers or Blade Enclosures. The kit contains stabilizing feet and appropriate hardware for a fast, easy form factor change. Each Tower Conversion Kit can support one UPS and up to two Extended Runtime Modules.

Related Options

Extended Runtime Module	HP R/T3000 Extended Runtime Module	AF455A
UPS Management	HP UPS Network Module	AF465A
HP Care Pack	HP Install Universal Power Supply 3KVA to Below 6KVA Service	U4693E



Model Matrix

UPS Models

Part Number	Operating Voltage Settings	Power Out (VA/Watts)	Input Connection	Output Connection
AF466A Low Voltage (NA/JPN)	100, 110, 120, 127	2880/2700	L5-30P, 3m cord	LS1 ² : 2x NEMA 5-20 outlets, 1 x NEMA L5-30R LS2 ³ : 2x NEMA 5-20 outlets
AF467A High Voltage (NA/JPN)	200/208 ¹ , Actual output voltage 204VAC	3300/3000	L6-20P, 3m cord	LS1 ² : 3x IEC C13, 1x IEC C-19, 1x NEMA L6-20R LS2 ³ : 3x IEC C13, 1x IEC C-19 NOTE: Includes one PDU Extension Bar. Each Extension Bar has 7x C13 outlets and plugs into a C-19 on the rear of the UPS.
AF468A (International)	220, 230, 240	3300/3000	Detachable IEC C-20 inlet plug	LS1 ² : 3x IEC C13, 1x IEC C-19 LS2 ³ : 3x IEC C13, 1x IEC C-19 NOTE: Includes one PDU Extension Bar. Each Extension Bar has 7x C13 outlets and plugs into a C-19 on the rear of the UPS.

¹ Factory default setting.

² LS1 = Load Segment 1

³ LS2 = Load Segment 2

Kit Contents

- HP UPS R/T3000 G2
- Power Products Documentation CD
- Depth adjustable fixed rack mounting rails, mounting brackets, cord retention clips
- Rack to Tower Conversion Kit and floor stand
- Communications cables
- AF453A and AF454A also includes 1 PDU Extension Bar (7 x C13 outlets each)

Estimated Backup Times Chart (Minutes)

Low Voltage NA/JPN model
(2880VA / 2700 Watt)

Load (Percent*)	Estimates battery runtime (Minutes)	With One Extended Runtime Module (Minutes)	With Two Extended Runtime Modules (Minutes)
540W (20%)	45	142	256
1350W (50%)	15	55	99
2160W (80%)	7	34	60
2700W (100%)	5	26	47

NOTE: Backup times are estimated for typical applications. Actual performance will depend on load and battery conditions.

High Voltage NA/JPN and Int'l model
(3300VA / 3000 Watt)

Load (Percent*)	Estimated battery runtime (Minutes)	With One Extended Runtime Module (Minutes)	With Two Extended Runtime Modules (Minutes)
600W (20%)	40	125	225
1500W (50%)	12	50	99
2400W (80%)	6	30	60
3000W (100%)	4	24	47

NOTE: Backup times are estimated for typical applications. Actual performance will depend on load and battery conditions.

Technical Specifications

Unit Dimensions (HxWxD)	3.5 x 17.5 x 25 inches / 8.9 x 44.5 x 63.5 cm
Shipping Dimensions	11.25 x 23.48 x 36.25 inches / 28.57 x 59.64 x 92.07 cm
Unit Weight	82 lbs/37 kg
Shipping Weight	89 lbs UPS and 127 lbs ERM / 40.37 kg & 57.6 kg
BTU Break Down	BTU On Line 540 BT/hr BTU On Battery 1138 BTU/hr Battery Type 12 V, 5 AH, sealed, maintenance-free, rechargeable, valve regulated lead-acid batteries with a 3-5 year service life at 25C (77F).
Electrical Input	Voltage Range See Model Matrix for nominal and user selectable voltage settings Frequency 50/60 Hz Online Efficiency 95% REPO Remote Emergency Power-Off disables AC power to load Online Regulation -10% to +6% of nominal voltage
Electrical Output	On battery Regulation ±5% of nominal voltage Voltage Wave Form Sine wave Connections See Model Selection Matrix; divided into 2 Load Segments Output Protection Re-settable circuit protectors Type Maintenance-free, sealed, valve-regulated lead acid (VRLA)
Battery	Extended Batteries Up to two ERMs supported Backup Time See Backup Times Chart Recharge Time <3 hours to 80% usable capacity; <48 hours for complete recharge Serial Ports Standard DB-9 and USB ports (ships with communication cables)
Communications	Option Slot One Option Cards HP UPS Network Module LED Indicators LED and switch membrane integrated into the front panel Software HP Power Protector software available
Environmental and Safety	Operating Temperature 10°C to 40°C (50°F to 104°F); UL-tested at 25°C (77°F) Non-operating Temperature -20°C to 50°C (-4°F to 122°F) Operating Humidity 20% to 80% (non-condensing) Storage Humidity 5% to 95% Operating Altitude Up to 6,562 ft (2000 m) above sea level Transit Altitude 49,212 ft (15,000 m) above sea level Audible Noise <45db in normal operation. <50db on battery operation Safety Markings NA/JPN: UL, cUL Int'l: GS, CE, GOST Safety Certifications UL1778, UL60950-1; CSA22.2 No.107.3-05,; EN60950-1 IEC62040-1-1 REPO Port Meets NEC code 645-10 and 645-11 and UL requirements



Technical Specifications

Environment-friendly Products and Approach

End-of-life Management and Recycling

Hewlett-Packard offers end-of-life HP product return, trade-in, and recycling programs in many geographic areas. For trade-in information, please go to: <http://www.hp.com/go/green>. To recycle your product, please go to: <http://www.hp.com/go/green> or contact your nearest HP sales office. Products returned to HP will be recycled, recovered or disposed of in a responsible manner.

The EU WEEE directive (2002/95/EC) requires manufacturers to provide treatment information for each product type for use by treatment facilities. This information (product disassembly instructions) is posted on the Hewlett Packard web site at: <http://www.hp.com/go/green>. These instructions may be used by recyclers and other WEEE treatment facilities as well as HP OEM customers who integrate and re-sell HP equipment.

© Copyright 2011 Hewlett-Packard Development Company, L.P.
The information contained herein is subject to change without notice.

The only warranties for HP products and services are set forth in the express warranty statements accompanying such products and services. Nothing herein should be construed as constituting an additional warranty. HP shall not be liable for technical or editorial errors or omissions contained herein.

