

LU 10.16/02/90 4.5SN GN BX

Weidmüller Interface GmbH & Co. KG
 Klingenbergstraße 26
 D-32758 Detmold
 Germany

www.weidmueller.com

Product image

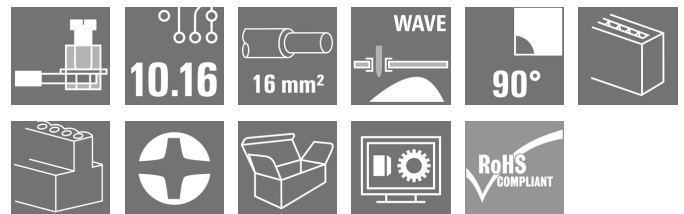

This PCB terminal provides connections for 76 A and 16 mm² conductor cross-section with proven clamping yoke connection at 10.16 mm pitch, conductor outlet direction in 90° design.

General ordering data

Version	Printed circuit board terminals, 10.16 mm, Number of poles: 2, 90°, Solder pin length (l): 4.5 mm, tinned, Pale green, Clamping yoke connection, Clamping range, max. : 16 mm ² , Box
Order No.	1010950000
Type	LU 10.16/02/90 4.5SN GN BX
GTIN (EAN)	4032248717385
Qty.	20 pc(s).
Product data	IEC: 1000 V / 76 A / 0.5 - 16 mm ² UL: 300 V / 65 A / AWG 26 - AWG 6
Packaging	Box

Creation date September 8, 2024 10:47:10 AM CEST

LU 10.16/02/90 4.5SN GN BX

Weidmüller Interface GmbH & Co. KG

Klingenbergstraße 26

D-32758 Detmold

Germany

www.weidmueller.com

Technical data

Dimensions and weights

Depth	18.3 mm	Depth (inches)	0.72 inch
Height	33 mm	Height (inches)	1.299 inch
Height of lowest version	28.5 mm	Width	20.32 mm
Width (inches)	0.8 inch	Net weight	19.15 g

System parameters

Product family	OMNIMATE Power - series LU	Wire connection method	Clamping yoke connection
Mounting onto the PCB	THT solder connection	Conductor outlet direction	90°
Pitch in mm (P)	10.16 mm	Pitch in inches (P)	0.4 "
Number of poles	2	Pin series quantity	1
Fitted by customer	Yes	Number of rows	1
Max. adjacent poles per row	10	Solder pin length (l)	4.5 mm
Solder pin dimensions	1.2 x 1.2 mm	Solder pin dimensions = d tolerance	0 / -0,15 mm
Solder eyelet hole diameter (D)	1.6 mm	Solder eyelet hole diameter tolerance (D)+	0,1 mm
Number of solder pins per pole	2	Screwdriver blade	1.0 x 5.5
Screwdriver blade standard	DIN 5264	Tightening torque, min.	1.2 Nm
Tightening torque, max.	2.2 Nm	Clamping screw	M 4
Stripping length	12 mm	L1 in mm	10.16 mm
L1 in inches	0.4 "	Touch-safe protection acc. to DIN VDE 0470	IP20 plugged/ IP10 unplugged
Touch-safe protection acc. to DIN VDE 57 106	Safe from finger touch	Protection degree	IP20
Volume resistance	0.50 mΩ		

Material data

Insulating material	Wemid (PA)	Colour	Pale green
Colour chart (similar)	RAL 6021	Insulating material group	I
Comparative Tracking Index (CTI)	≥ 600	UL 94 flammability rating	V-0
Contact material	Cu-alloy	Contact surface	tinned
Layer structure of solder connection	1.5...3 μm Ni / 4...6 μm Sn matt	Storage temperature, min.	-40 °C
Storage temperature, max.	70 °C	Operating temperature, min.	-50 °C
Operating temperature, max.	120 °C	Temperature range, installation, min.	-25 °C
Temperature range, installation, max.	120 °C		

Conductors suitable for connection

Clamping range, min.	0.14 mm ²
Clamping range, max.	16 mm ²
Wire connection cross section AWG, min.	AWG 22
Wire connection cross section AWG, max.	AWG 8
Solid, min. H05(07) V-U	0.5 mm ²
Solid, max. H05(07) V-U	16 mm ²
Stranded, min. H07V-R	6 mm ²
Stranded, max. H07V-R	16 mm ²
Flexible, min. H05(07) V-K	0.5 mm ²
Flexible, max. H05(07) V-K	16 mm ²
w. plastic collar ferrule, DIN 46228 pt 4, min.	2.5 mm ²
w. plastic collar ferrule, DIN 46228 pt 4, max.	10 mm ²

Creation date September 8, 2024 10:47:10 AM CEST

Catalogue status 31.08.2024 / We reserve the right to make technical changes.

LU 10.16/02/90 4.5SN GN BX

Weidmüller Interface GmbH & Co. KG
 Klingenbergstraße 26
 D-32758 Detmold
 Germany

www.weidmueller.com

Technical data

w. wire end ferrule, DIN 46228 pt 1, min.	2.5 mm ²			
w. wire end ferrule, DIN 46228 pt 1, max.	10 mm ²			
Plug gauge in accordance with EN 60999 a x b; ø	5.4 mm x 5.1 mm; 5.3 mm			
Clampable conductor	Cross-section for conductor connection	Type	fine-wired	
		nominal	2.5 mm ²	
	wire end ferrule	Stripping length	nominal	12 mm
		Recommended wire-end ferrule	H2.5/12	
		Stripping length	nominal	14 mm
		Recommended wire-end ferrule	H2.5/19D BL	
	Cross-section for conductor connection	Type	fine-wired	
		nominal	4 mm ²	
	wire end ferrule	Stripping length	nominal	12 mm
		Recommended wire-end ferrule	H4.0/12	
		Stripping length	nominal	14 mm
		Recommended wire-end ferrule	H4.0/20D GR	
	Cross-section for conductor connection	Type	fine-wired	
		nominal	6 mm ²	
	wire end ferrule	Stripping length	nominal	12 mm
		Recommended wire-end ferrule	H6.0/12	
		Stripping length	nominal	14 mm
		Recommended wire-end ferrule	H6.0/20 SW	
	Cross-section for conductor connection	Type	fine-wired	
		nominal	10 mm ²	
wire end ferrule	Stripping length	nominal	15 mm	
	Recommended wire-end ferrule	H10.0/22 EB		
	Stripping length	nominal	12 mm	
	Recommended wire-end ferrule	H10.0/12		

Reference text Length of ferrules is to be chosen depending on the product and the rated voltage.. The outside diameter of the plastic collar should not be larger than the pitch (P)

Rated data acc. to IEC

tested acc. to standard	IEC 60664-1, IEC 61984	Rated current, min. number of poles (Tu=20°C)	76 A
Rated current, max. number of poles (Tu=20°C)	72 A	Rated current, min. number of poles (Tu=40°C)	76 A
Rated current, max. number of poles (Tu=40°C)	62 A	Rated voltage for surge voltage class / pollution degree II/2	1,000 V
Rated voltage for surge voltage class / pollution degree III/2	690 V	Rated voltage for surge voltage class / pollution degree III/3	690 V
Rated impulse voltage for surge voltage class/ pollution degree II/2	4 kV	Rated impulse voltage for surge voltage class/ pollution degree III/2	6 kV
Rated impulse voltage for surge voltage class/ contamination degree III/3	6 kV	Short-time withstand current resistance	2 x 1s with 700 A

LU 10.16/02/90 4.5SN GN BX

Weidmüller Interface GmbH & Co. KG
 Klingenbergstraße 26
 D-32758 Detmold
 Germany

www.weidmueller.com

Technical data

Rated data acc. to CSA

Institute (CSA)



Certificate No. (CSA)

200039-1198743

Rated voltage (Use group B / CSA)	300 V
Rated voltage (Use group D / CSA)	300 V
Rated current (Use group C / CSA)	65 A
Wire cross-section, AWG, min.	AWG 22
Reference to approval values	Specifications are maximum values, details - see approval certificate.

Rated voltage (Use group C / CSA)	150 V
Rated current (Use group B / CSA)	65 A
Rated current (Use group D / CSA)	10 A
Wire cross-section, AWG, max.	AWG 6

Rated data acc. to UL 1059

Institute (UR)



Certificate No. (UR)

E60693

Rated voltage (Use group B / UL 1059)	300 V
Rated voltage (Use group D / UL 1059)	600 V
Rated current (Use group C / UL 1059)	65 A
Wire cross-section, AWG, min.	AWG 26
Reference to approval values	Specifications are maximum values, details - see approval certificate.

Rated voltage (Use group C / UL 1059)	150 V
Rated current (Use group B / UL 1059)	65 A
Rated current (Use group D / UL 1059)	5 A
Wire cross-section, AWG, max.	AWG 6

Packing

Packaging	Box	VPE length	125 mm
VPE width	90 mm	VPE height	35 mm

Type tests

Test: Durability of markings	Test	mark of origin, type identification, type of material, rated cross-section, approval marking CSA, approval marking UL, pitch, durability
	Evaluation	available

LU 10.16/02/90 4.5SN GN BX

Weidmüller Interface GmbH & Co. KG
 Klingenbergstraße 26
 D-32758 Detmold
 Germany

www.weidmueller.com

Technical data

Test: Clampable cross section	Conductor type	Type of conductor and conductor cross-section H05V-K0.5
		Type of conductor and conductor cross-section H05V-U0.5
		Type of conductor and conductor cross-section H07V-K10
		Type of conductor and conductor cross-section H07V-U10
		Type of conductor and conductor cross-section H07V-U16
		Type of conductor and conductor cross-section AWG 8/19
		Type of conductor and conductor cross-section AWG 22/1
		Type of conductor and conductor cross-section AWG 22/19
	Evaluation	passed
Test for damage to and accidental loosening of conductors	Standard	EN 60947-1/1991 section 8.2.4.3
	Requirement	0.3 kg
	Conductor type	Type of conductor and conductor cross-section H05V-K0.5
		Type of conductor and conductor cross-section H05V-U0.5
		Type of conductor and conductor cross-section AWG 22/1
		Type of conductor and conductor cross-section AWG 22/19
	Evaluation	passed
	Requirement	2.0 kg
	Conductor type	Type of conductor and conductor cross-section H07V-K10
		Type of conductor and conductor cross-section H07V-U10
		Type of conductor and conductor cross-section AWG 8/19
	Evaluation	passed
	Requirement	2.9 kg
	Conductor type	Type of conductor and conductor cross-section H07V-U16
	Evaluation	passed

LU 10.16/02/90 4.5SN GN BX

Weidmüller Interface GmbH & Co. KG
 Klingenbergstraße 26
 D-32758 Detmold
 Germany

www.weidmueller.com

Technical data

Pull-out test	Standard	EN 60947-1/1991 section 8.2.4.4
	Requirement	≥20 N
	Conductor type	Type of conductor and AWG 22/1 conductor cross-section
		Type of conductor and AWG 22/19 conductor cross-section
	Evaluation	passed
	Requirement	≥30 N
	Conductor type	Type of conductor and H05V-K0.5 conductor cross-section
		Type of conductor and H05V-U0.5 conductor cross-section
	Evaluation	passed
	Requirement	≥ 90N
	Conductor type	Type of conductor and H07V-K10 conductor cross-section
		Type of conductor and H07V-U10 conductor cross-section
		Type of conductor and AWG 8/19 conductor cross-section
	Evaluation	passed
	Requirement	≥100 N
	Conductor type	Type of conductor and H07V-U16 conductor cross-section
Evaluation	passed	

Classifications

ETIM 6.0	EC002643	ETIM 7.0	EC002643
ETIM 8.0	EC002643	ETIM 9.0	EC002643
ECLASS 9.0	27-44-04-01	ECLASS 9.1	27-44-04-01
ECLASS 10.0	27-44-04-01	ECLASS 11.0	27-46-01-01
ECLASS 12.0	27-46-01-01	ECLASS 13.0	27-46-01-01
ECLASS 14.0	27-46-01-01		

Environmental Product Compliance

REACH SVHC	/
RoHS Compliance Status	Compliant without exemption

LU 10.16/02/90 4.5SN GN BX

Weidmüller Interface GmbH & Co. KG
 Klingenbergstraße 26
 D-32758 Detmold
 Germany

www.weidmueller.com

Technical data

Important note

IPC conformity	Conformity: The products are developed, manufactured and delivered according international recognized standards and norms and comply with the assured properties in the data sheet resp. fulfill decorative properties in accordance with IPC-A-610 "Class 2". Further claims on the products can be evaluated on request.
Notes	<ul style="list-style-type: none"> • Additional variants on request • Rated current related to rated cross-section & min. No. of poles. • Wire end ferrule without plastic collar to DIN 46228/1 • Wire end ferrule with plastic collar to DIN 46228/4 • P on drawing = pitch • Rated data refer only to the component itself. Clearance and creepage distances to other components are to be designed in accordance with the relevant application standards. • Long term storage of the product with average temperature of 50 °C and maximum humidity 70%, 36 months

Approvals

Approvals



ROHS	Conform
UL File Number Search	UL Website
Certificate No. (UR)	E60693

Downloads

Approval/Certificate/Document of Conformity	Declaration of the Manufacturer
Engineering Data	CAD data – STEP
Product Change Notification	20220201 Visual change OMNIMATE® Power PCB terminal blocks and connectors 20220201 Visuelle Änderung OMNIMATE® Power Leiterplattenklemmen und -steckverbinder
User Documentation	QR-Code product handling video
Catalogues	Catalogues in PDF-format
Brochures	FL DRIVES EN MB DEVICE MANUF. EN FL DRIVES DE FL APPL_INVERTER EN FL_BASE_STATION_EN FL ELEVATOR EN FL POWER SUPPLY EN FL 72H SAMPLE SER EN PO OMNIMATE EN

LU 10.16/02/90 4.5SN GN BX

Weidmüller Interface GmbH & Co. KG
 Klingenbergstraße 26
 D-32758 Detmold
 Germany

www.weidmueller.com

Drawings

Product image

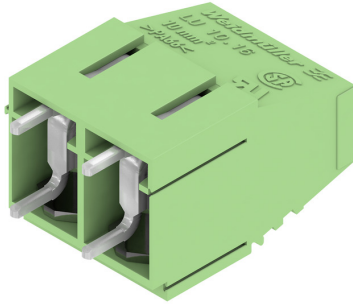

Dimensional drawing

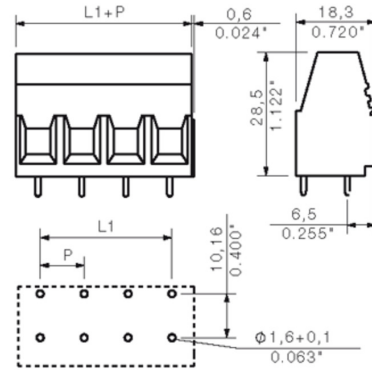

Graph

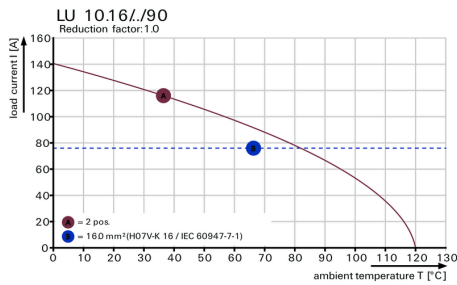

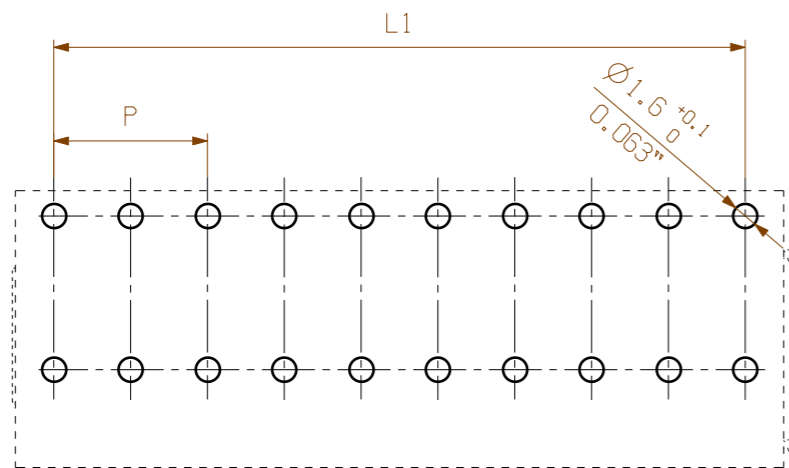
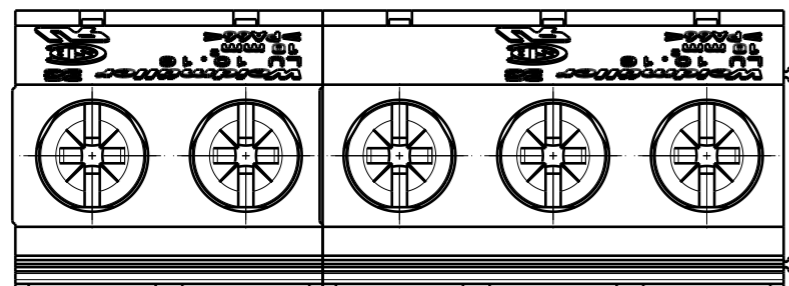
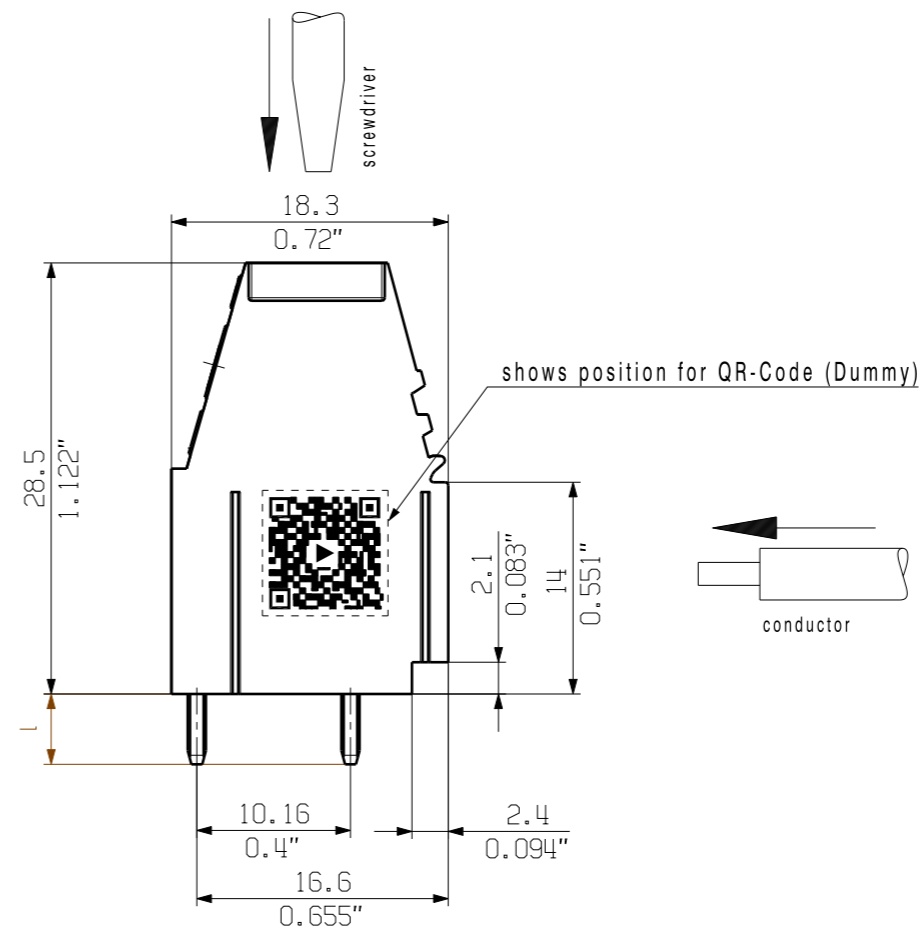
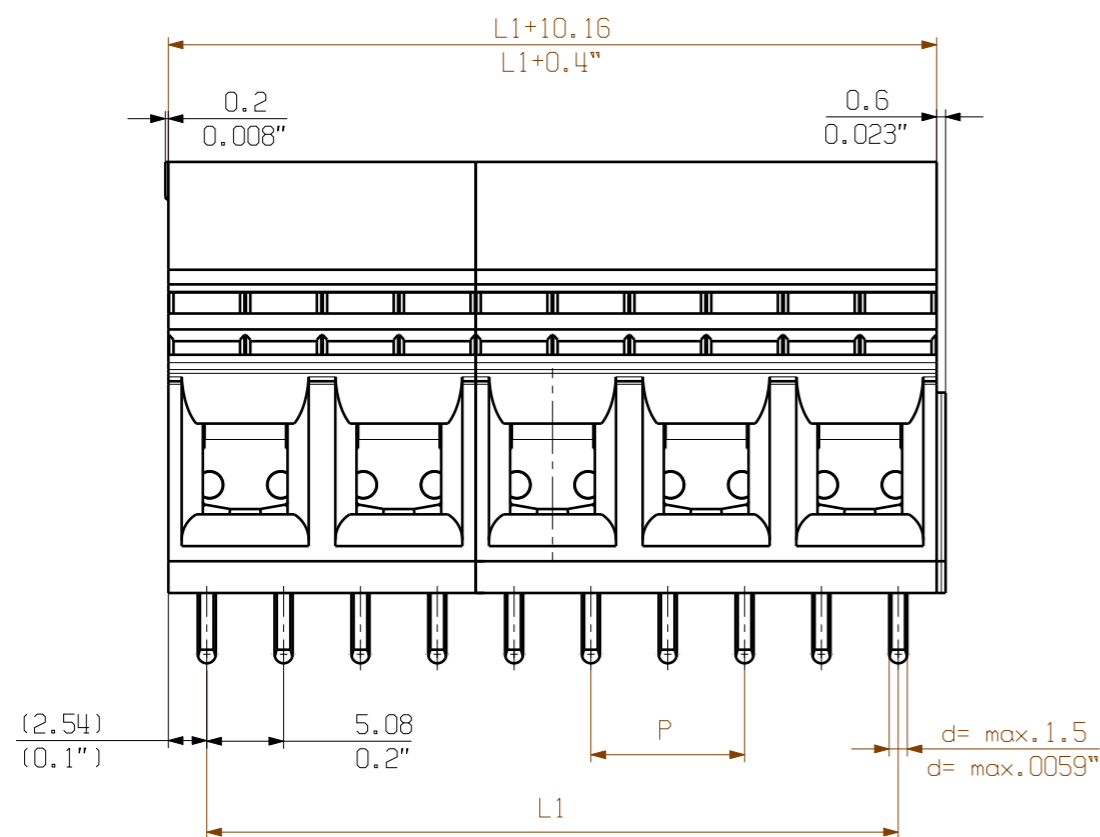

12	116,84	4,600
11	106,68	4,200
10	96,52	3,800
9	86,36	3,400
8	76,20	3,000
7	66,04	2,600
6	55,88	2,200
5	45,72	1,800
4	35,56	1,400
3	25,40	1,000
2	15,24	0,600
n	L1[mm]	L1 [Inch]

shown : LU 10.16/05/90

l = solder pin length (4.5/3.2)

P = pitch (10.16)

n = no of poles

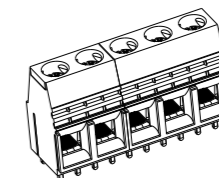

For the mounting of PCBs, it should be noted that the rated data relates only to the PCB components alone. The necessary creepage and clearance paths must be observed in connection with the respective applicant in accordance to IEC 664 / VDE 0110. The current-carrying capacity and pitch tolerance is to be determined according to DIN IEC 326 part 3 very fine.

Weidmüller PCB components are tested to the DIN EN 61984 standard, and are valid for its field of application. Provided that the components are used to the intended purpose, all requirements with respect to the occurring of electrical, mechanical, thermic and corrosive stress will be satisfied.

GENERAL TOLERANCE: DIN ISO 2768-mK 	102098	04	Prim PLM Part No.: 017733	Prim ERP Part No.: 1635920000
	First Issue Date 16.02.2018			21310 Drawing no. Issue no. 10 Sheet 01 of 01 sheets
	Date 16.02.2018 Name Administrator	Date 12.11.2018 Name Lang, Thomas	LU 10.16/././90 LEITERPLATTENKLEMME PCB TERMINAL Product file: 7232 LU 10.16	
Scale: 2:1 Size: A3	Drawn Responsible Approved	Date Name		

Recommended wave soldering profiles

Weidmüller Interface GmbH & Co. KG
 Klängenbergstraße 16
 D-32758 Detmold
 Germany
 Fon: +49 5231 14-0
 Fax: +49 5231 14-292083
 www.weidmueller.com

Single Wave:



Double Wave:



Wave soldering profiles

Wired connection elements should be processed in accordance with the DIN EN 61760-1 standard. We have included two recommendations for practical wave soldering profiles, with which Weidmüller PCB terminals and connectors are qualified.

When choosing a suitable profile for your application, the following factors also need to be considered:

- PCB thickness
- Proportion of Cu in the layers
- Single/double-sided assembly
- Product range
- Heating and cooling rates

The single and double wave profiles each indicate the recommended operating range, including the maximum soldering temperature of 260°C. In practice, the maximum soldering temperature is quite often well below the above maximum profile.