

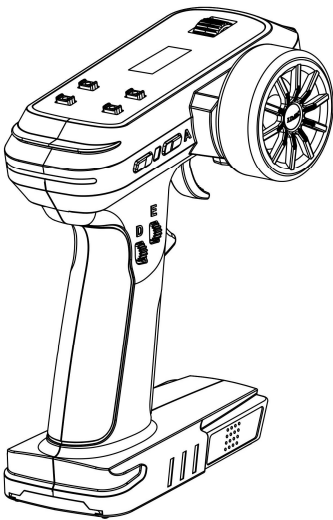

LDARC O.  
TELEMETRY SYSTEM

# CT01 遥控器



第二页中文

**ENGLISH PAGE 7**

版本 21228

# CT01 遥控器使用说明书

- LDARC O-双向 2.4Ghz 无线协议
- 遥测(回传)动力电池电压, 支持自定义电压报警值
- 8 通道输出, 内置 5 组模型文件
- 6 个开关通道全部支持输出自定义
- 震动和声音报警
- 支持双路履带(坦克)模式
- 按键灯光支持白色、彩色或关闭
- 遥控器固件升级
- 中英文菜单界面
- 接收机实时信号强度指示, 支持信号连接和断开提醒
- 除转向和油门之外的其他 6 个开关通道全部支持重映射
- 8 通道独立失控保护设置
- 可拆卸 18650 电池, 标准 USB Type-C 充电接口
- 个性化氛围尾灯
- 50Hz / 100Hz / 200Hz 舵机速度

## 警告

- 本产品不是玩具, 用户需要有熟练操作经验, 错误的使用可能造成人身伤害和设备损坏, 使用前请仔细阅读说明书, 我们不承担因使用本产品而引起的任何责任。
- 禁止在雷雨等恶劣环境下使用本产品。
- 对网时请断开电源与接收机的连接, 防止马达错误启动产生危险。
- 当接收机和遥控器距离较远、有障碍物阻挡、使用环境内存在无线电干扰等情况下, 接收机可能存在失控风险, 务必根据实际场景设置合理的失控保护值, **谨防马达动力输出的机械损伤, 在确保安全的前提下**, 关闭遥控器电源以验证失控保护是否正确执行。

## 功能

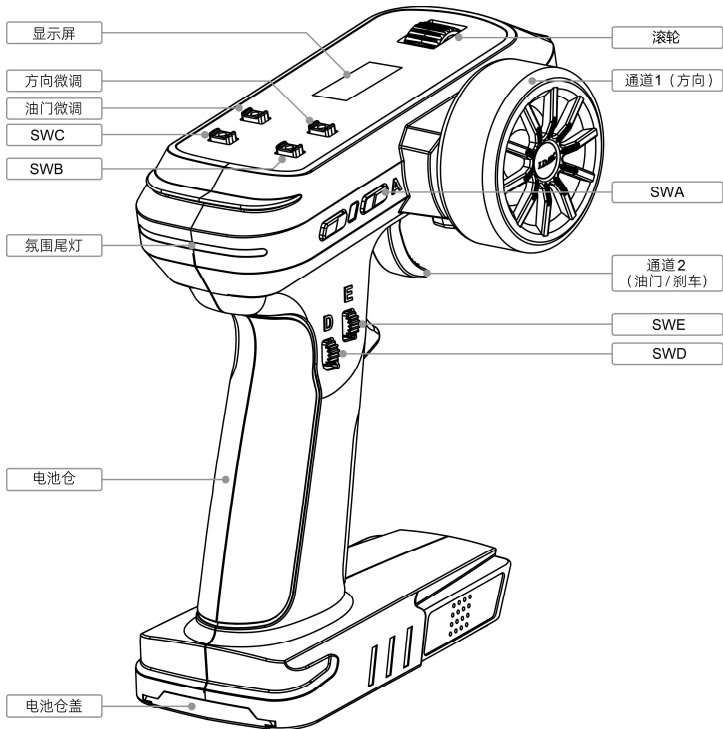

## 电池和充电

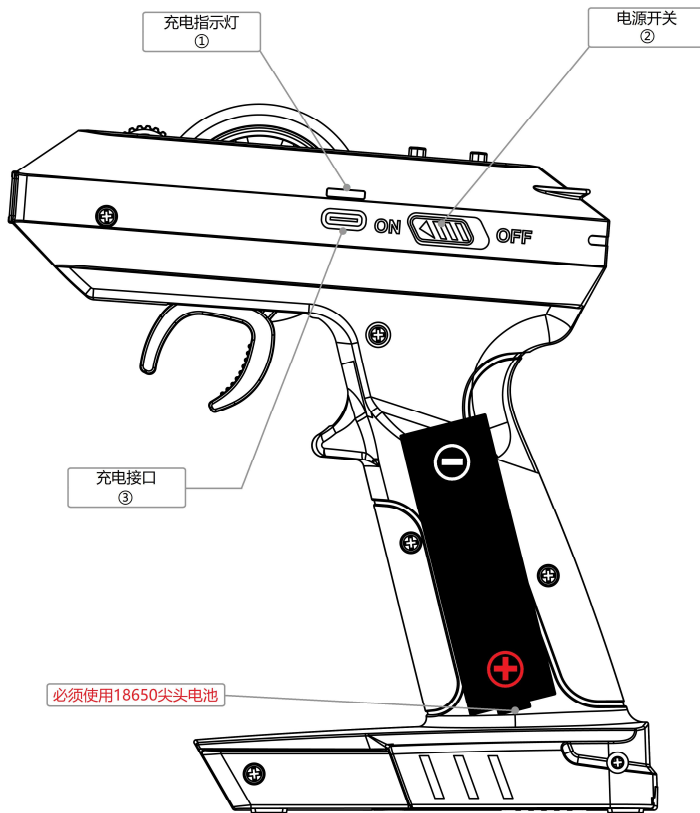

■ 安装电池：打开电池舱盖，按照上图标注的极性安装电池，本产品只支持锂离子或锂聚合物 18650 尖头电池，充电限制电压 4.2V，放电截止电压 3.5V±0.1V。

■ ①：充电时红色指示灯点亮，充电结束指示灯熄灭。

■ ②：电源开关 ON 位置开机，OFF 位置关机。

■ ③：标准 USB Type-C 充电接口，可直接使用市面上绝大部分手机充电器、氯化锂充电器或者充电宝。

■ 注意！给劣质、受到过剧烈冲击、有机械形变或过放电的电池充电可能存在起火风险，充电时建议有人值守。

■ 本产品充电电流是 600mA，如果用户使用 1200mAh 容量的电池充满大约需要 2 小时，2400mAh 容量充满大约需要 4 小时。

■ 使用少部分老式电路的 USB 口或者通过 USB 集线器充电时，可能因为供电电流不足导致充电时间过长甚至无法充满。

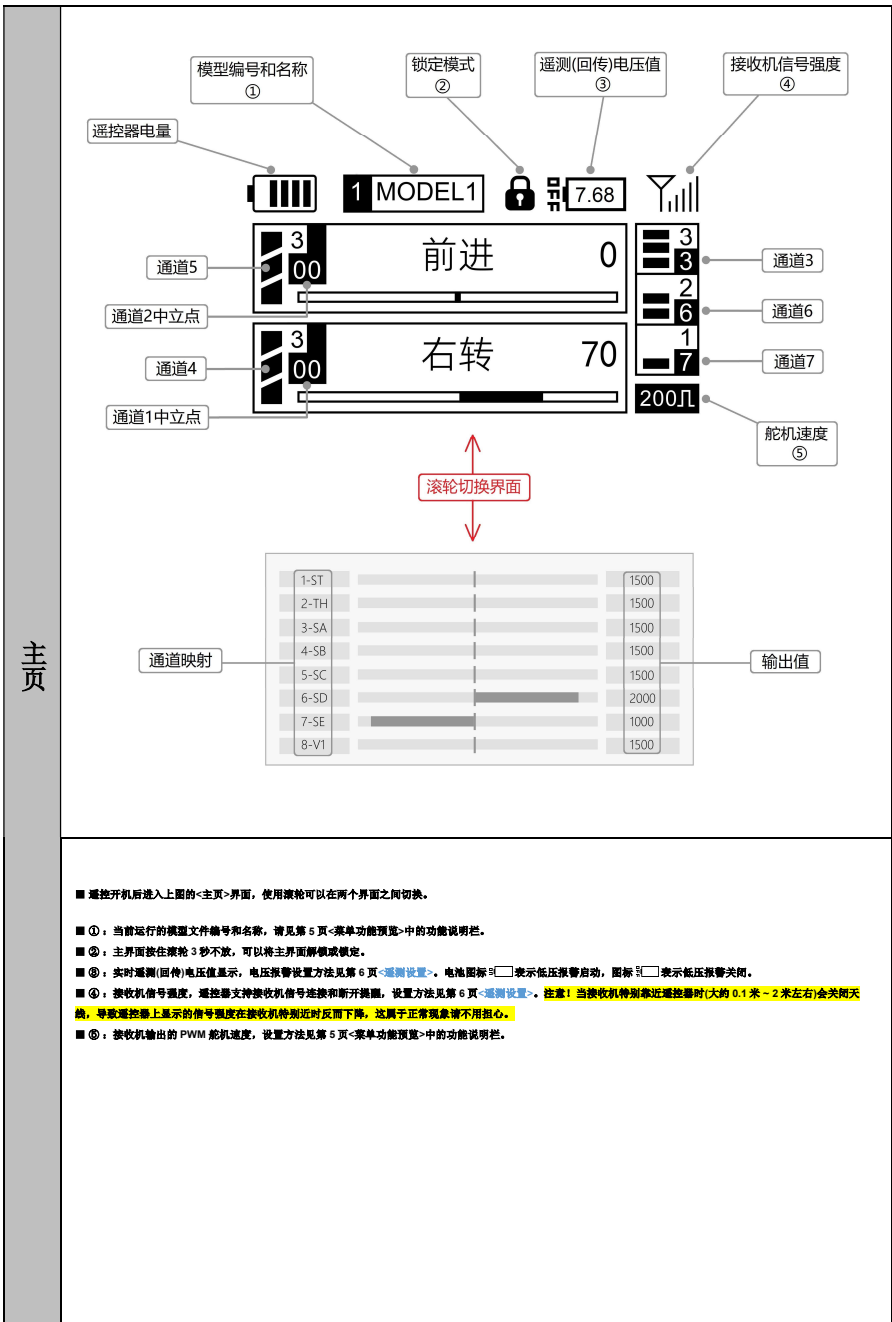

主页

■ 遥控开机后进入上面的<主页>界面，使用滚轮可以在两个界面之间切换。

■ ①：当前运行的模型文件编号和名称，请见第 5 页<菜单功能预览>中的功能说明栏。

■ ②：主界面按住滚轮 3 秒不放，可以将主界面解锁或锁定。

■ ③：实时遥测(回传)电压值显示，电压报警设置方法见第 6 页<遥测设置>。电池图标  表示低压报警启动，图标  表示低压报警关闭。

■ ④：接收机信号强度，遥控器支持接收机信号连接和断开调整，设置方法见第 6 页<遥测设置>。**注意！**当接收机特别靠近遥控器时(大约 0.1 米 - 2 米左右)会关闭天线，导致遥控器上显示的信号强度在接收机特别近时反而下降，这属于正常现象请不用担心。

■ ⑤：接收机输出的 PWM 舵机速度，设置方法见第 5 页<菜单功能预览>中的功能说明栏。

■ <模型设置>是编号 0/1/2/3/4 共五组模型文件的设置页面，菜单栏红字的 M0 代表当前运行的模型文件。

遥控设置 M0	高级设置 M0	功能说明
退出	退出	
English	模型编号 0	切换模型文件，编号 0/1/2/3/4 共五组
模型设置	模型名称	自定义名称
高级设置	方向设置	CH1 方向通道的反向、行程和辅助微调
关于	油门设置	CH2 油门通道的反向、行程和辅助微调
	通道重映射	SWA/B/C/D/E 和虚拟电位器通道 SV1 共 6 个开通道的重映射设置
	按键自定义	定义开关通道的档位输出值，最大和最小设置值是行程极值，请阅读蓝字的 #注意事项
	失控保护	见本页 <失控保护>
	舵机速度	设置接收机输出的 PWM 舵机速度
	调速设置	见第 6 页 <调速设置>
	尾灯设置	自定义尾灯颜色和亮度
	遥控器模式	<普通车控>-<双路履带(坦克)>模式切换

# 注意事项：

■ SWA/B/C 是三档开关，用户可自定义三个档位的数值，数值范围是 900us - 2100us。

■ SWD 是两档开关，用户可自定义两个档位的数值，数值范围同上。

■ SWE 是触发开关，客户可设置两个数值，按下时发送一个值，松手发送另外一个值，数值范围同上。

■ SV1 是虚拟电位器通道，客户直接设置虚拟电位器的输出值，数值范围同上。

■ <高级设置>菜单是遥控器硬件相关的设置。

遥控设置 M0	高级设置 M0	功能说明
退出	退出	
English	开盖检测码	
模型设置	关盖检测码	见第 6 页 <对码>
高级设置	屏幕亮度	LCD 背光亮度，设置为 0 可以关闭背光
关于	LCD 显示对比度	LCD 显示对比度，用户根据现场调节
	按键灯颜色	按键指示灯 <彩色>或 <白>模式
	按键灯亮度	按键指示灯亮度，设置为 0 可以关闭按键灯
	校准遥控器	重新校准遥控器方向舵和油门扳机
	恢复出厂设置	重置所有遥控器设置和模型文件出厂值，恢复出厂设置后需要执行-校准遥控器-操作

■ <失控保护>设置菜单，请仔细阅读功能说明栏中关于失控保护设置的说明。

遥控设置 M0	失控保护 M0	失控保护 M0
退出	退出	退出
English	通道编号 0	CH-1 停止
模型设置	模型名称	CH-2 停止
高级设置	方向设置	CH-3 保持
关于	油门设置	CH-4 保持
	通道重映射	CH-5 保持
	按键自定义	CH-6 保持
	失控保护	CH-7 保持
	舵机速度 50	CH-8 保持
	调速设置	
	尾灯设置	
	遥控器模式	

功能说明

失控保护支持<保持>、<停止>、<数值自定义>三种模式

■ <保持>模式：当失控发生时保持输出最后的 PWM 信号输出不变，该功能一般用于普通开关通道，用于车门、大灯等辅助控制。

■ <停止>模式：当失控发生时无信号输出，将失控时的控制权下放给连接的设备。该功能一般用于电机，使用前请仔细阅读说明书确保使用安全。

■ <数值自定义>模式：当失控发生时输出用户自定义的 PWM 信号值。该功能仅限专家，请谨慎使用。

注意事项：

■ 务必根据实际场景设置合理的失控保护值，请拆除马达动力输出的机械齿轮，在确保安全的前提下，关闭遥控器电源以验证失控保护是否正确执行。

■ 失控保护和舵机速度设置结束后接收机需要最多 20 秒才能执行设置参数。

■ 接收机刚上电时所有通道都是 50Hz 舵机速度输出，一旦接收到遥控器信号将按照用户设置的舵机速度和失控保护工作，此过程同样需要最多 20 秒。

遥测设置

■ 接收机遥测(回传)电压报警设置、信号连接和断开功能等功能设置。

遥控器设置	接收器设置	遥测设置	功能说明
退出	退出	退出	
English	模型编号	连接弹窗 <b>启动</b>	接收机连接或断开时遥控器震动和蜂鸣提醒
模型设置	模型名称	低压报警 <b>关闭</b>	当遥测电压低于设置时遥控器震动和蜂鸣提醒
高级设置	方向设置	报警电压 <b>74</b>	遥测报警电压值，是否报警取决于<低压报警>
关于	油门设置	电压补偿 <b>0</b>	如果遥测显示电压与实际有偏差，此处可微调
	通道映射		
	通道映射		
	失控保护		
	舵机速度		
	遥测设置		
	尾灯设置		
	遥控器模式		

注意：<报警电压>是串联总电压的最低允许值，遥控器并不知道串联了几节电池，也不知道电池类型，客户需要报测实际使用情况设置总电压的最低<报警电压>，遥控器主页的电池图标  表示低压报警启动，图标  表示低压报警关闭。

对码

■ 遥控器中<对码>的菜单所在位置

遥控器设置	高级设置
退出	退出
English	开遥测对码
模型设置	关遥测对码
高级设置	屏幕亮度
关于	屏幕对比度
	按键灯颜色
	按键灯亮度
	校准遥控器
	恢复出厂设置

■ 接收机上电 10 秒内，按下<BIND>按钮不放直到指示灯**高速**快速闪烁，表示接收机已经进入对码模式，在遥控器<遥控器设置>，<高级设置>菜单中选择<开遥测对码>或<关遥测对码>，分别对应接收机的<遥测启动>或<遥测关闭>模式，接收机对码成功后指示灯将变为**红色**慢闪或**红色**慢闪，此时遥控器退出对码菜单，接收机需要重新上电才会正常工作。接收机指示灯的具体含义请参考接收机说明书。

■ <开遥测对码> & <遥测启动>模式：接收机与遥控器是双向通讯，接收机把遥测(回传)电压发送到遥控器上，用户可以在遥控器设置报警电压。遥控器内每个模型文件可以与多个<遥测启动>模式的接收机对码绑定，**但用户必须保证同一时刻只有一个接收机上电启动**，因为多个<遥测启动>模式的接收机同时工作会导致遥测(回传)数据混乱。

■ <关遥测对码> & <遥测关闭>模式：接收机与遥控器是单向通讯，此时遥控器无法查看接收机的遥测(回传)电压和信号强度。

注意事项：

■ 使用 LDARC 0 无线协议的 CT 系列遥控器内每个模型文件都有唯一 ID。该功能可保证接收机对码时是与遥控器内的模型文件绑定，**即使是同一台遥控器，没有与当前模型文件对码绑定的接收机将处于失控状态。**

参数

电气性能

- 工作电压：3.5V ~ 4.2V
- 额定电流：小于 90mA (关闭所有灯光)
- 额定电流：小于 300mA (所有灯光最大亮度)
- 充电电流：600mA
- 重量：240g(不含电池)

LDARC O<sub>2</sub> 协议

- 无线数据刷新时间：7.5ms
- 通讯码率：1Mbps
- 通道数据分辨率：11bit (2048)
- PWM 输出范围：900us ~ 1500us ~ 2100us
- 协议总通道数量：16 通道(CT01 使用前 8 通道)

8 通道硬件定义

- 2 个脉冲通道：转向和油门
- 3 个三档开关通道：SWA、SWB、SWC
- 1 个两档开关通道：SWD
- 1 个触发开关通道：SWE
- 1 个虚拟电位器通道：SV1

LDARC 0 无线协议支持的产品：

- 雷迪安 CT 系列遥控器
- 雷迪安 CR 系列接收机
- 雷迪安 X43 数模桌面越野车
- 雷迪安 M58 微型大脚车

WWW.LDARC.COM

雷迪安

# CT01 TRANSMITTER USER MANUAL

- LDARC O, bidirectional 2.4GHz wireless system
- Telemetry voltage for main battery, custom alert voltage
- 8 channels output, 5 model files
- 6 SW channels all support custom output PWM value
- Sound and vibration warning
- Support dual tracks (tank) mode
- Backlight of key support white / color / lights out mode
- Transmitter support firmware update
- English and Chinese language menu
- Wireless signal strength indication, receiver connect / disconnect alert
- 6 SW channels all support channel remap
- 8 channels independent failsafe setting
- Detachable 18650 battery, standard USB Type-C charging interface
- Custom RGB rear light
- 50Hz / 100Hz / 200Hz servo speed

## WARNING

- This product is not a toy, user need model hands-on experience. Please be careful when using, we do not assume responsibility for any property damage or personal injury caused by use this product.
- **DO NOT** using in thunderstorm, bad weather and harsh environments.
- Remove ESC and motor before run binding procedure or else may result in serious injury.
- Receiver may lose signal when the distance too far, sheltered by barrier or radio interference. Use reasonable failsafe setting. Under the premise of ensuring safety  
remove motor gear then power off transmitter to test failsafe working properly or not.

## FUNCTION

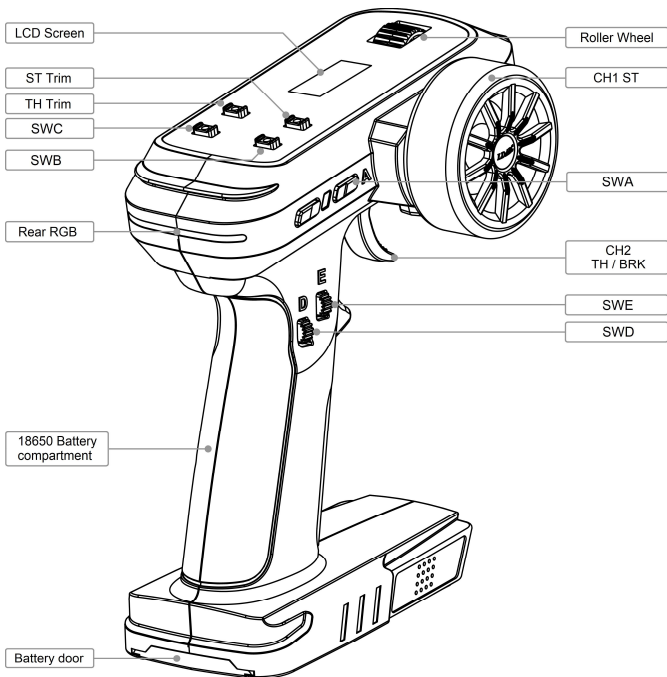

## BATTERY & CHARGING

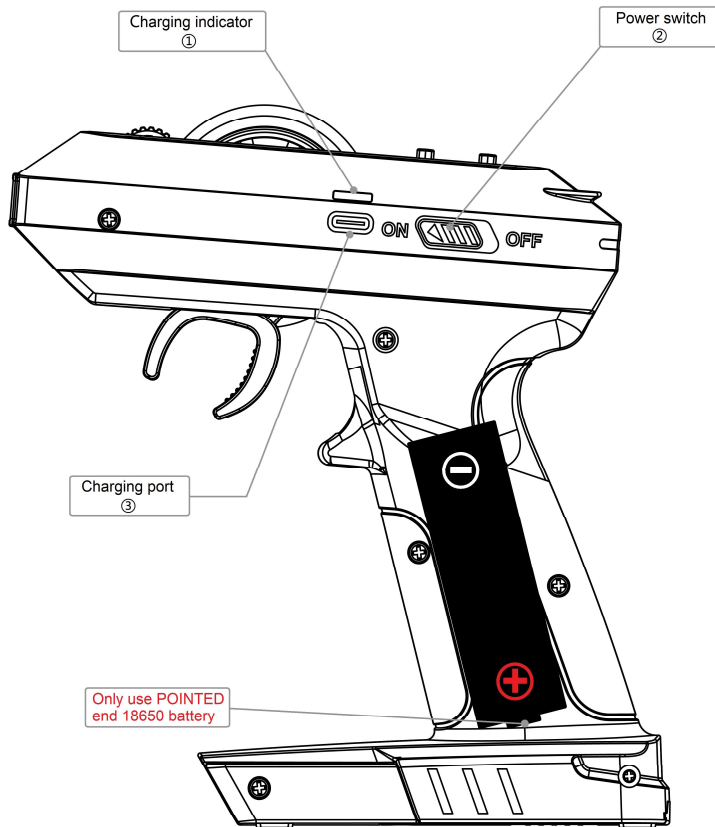

■ Installing battery : remove the battery door from the bottom of the transmitter, install battery as shown, ONLY use LI-Ion or LI-pol POINTED end 18650 battery, charging voltage 4.2V maximum.

■ ① : Red indicator on when charging, light off when charging finished.

■ ② : ON position power-up, OFF position power-off.

■ ③ : Standard USB Type-C charging interface can use most of mobile phone charger like normal USB charger, GaN charger or mobile power supply (Charge Pal).

■ Warning! Risk of explosion if use inferior, mechanical deformation, over discharge battery.

■ Transmitter charging current 600mA, fully charged need about 2 hours if use 1200mAh capacity battery, about 4 hours if use 2400mAh battery.

■ When charging using some old computer or USB hub, maybe cannot fully charged because current limit, please use mobile phone charger.



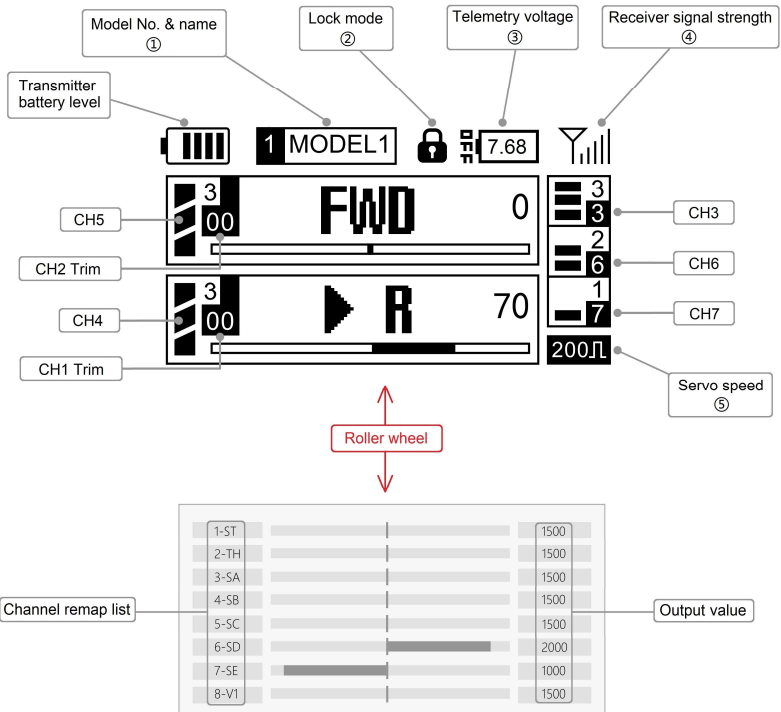

■ Transmitter will into <Main menu> after power-up, use roller wheel can switch between 2 page above.

■ ① : Current running model file number and name, more information see page 10 <MENU PREVIEW>.

■ ② : Press roller wheel and hold 3 seconds can lock or unlock main menu.

■ ③ : Telemetry voltage value display, low voltage alert setting see page 10 <TELEMETRY>. Battery icon  meaning LV Alert OFF, icon  meaning LV Alert ON.

■ ④ : Wireless signal strength level, receiver connect / disconnect alert setting see page 10 <TELEMETRY>. **Notice: receiver will turn antenna off when very close to transmitter (about 0.1 ~ 2.0 meters), this leads to the display signal strength level down, its normal no need to worry about.**

■ ⑤ : Servo speed, more information see page 10 <MENU PREVIEW>.

■ <Model Setting> is the setting page of five model files numbered 0/1/2/3/4, the red **M0** on menu bar indicate the current running model file.

Setting <b>M0</b>	Model Setting <b>M0</b>	Functional specifications
Exit	Exit	
切换到中文	Model No. <b>0</b>	Switch current running model file, number 0/1/2/3/4 total five model files
Model	Model Name	Custom model file name
Advanced	ST Setting	CH1 ST channel reverse, end point and sub trim
About	TH Setting	CH2 TH channel reverse, end point and sub trim
	CH Remap	Remap define of SWA/B/C/D/E and SV1
	SW Custom	Define SW channel output value, please read blue words <b>#Notice</b> below
	Failsafe	See <b>#Failsafe</b> => this page
	Servo SPD <b>50</b>	Setting receiver output servo speed (PWM speed)
	Telemetry	See page 10 <b>&lt;TELEMETRY&gt;</b>
	RGB	Custom RGB rear light color and brightness
	TX Type	<Normal car> or <Dual tracks (tank)> mode

**# Notice:**

- SWA/B/C are 3 gears structure, user can define 3 different output values, range is 900us ~ 2100us.
- SWD are 2 gears structure, user can define 2 different output values, range same as above.
- SWE is trigger structure, user can define 2 different output values, hold SWE will sent one value, release will sent another, range same as above.
- SV1 is virtual potentiometer, user can define potentiometer output values, range same as above.

■ <Advanced> is the setting page related to transmitter hardware.

Setting <b>M0</b>	Advanced <b>M0</b>	Functional specifications
Exit	Exit	
切换到中文	Bind TLM-On	See page 11 <b>&lt;BIND&gt;</b>
Model	Bind TLM-Off	
Advanced	LCD-BRT	LCD backlight brightness, turn off backlight if set to 0
About	LCD Contrast	LCD contrast
	SW-Color	The LED of SW key <Color> or <White> mode switch
	SW-BRT	The LED of SW key brightness, turn off LED if set to 0
	Calibration	Recalibration the ST and TH channels
	Reset	Reset to the factory default, <b>user need perform &lt;Calibration&gt; after &lt;Reset&gt;</b>

■ <Failsafe> menu, please read functional specifications below carefully before setting.

Setting <b>M0</b>	Model Setting <b>M0</b>	Failsafe <b>M0</b>
Exit	Exit	Exit
切换到中文	Model No. <b>0</b>	CH-1 <b>STP</b>
Model	Model Name	CH-2 <b>STP</b>
Advanced	ST Setting	CH-3 <b>HLD</b>
About	TH Setting	CH-4 <b>HLD</b>
	CH Remap	CH-5 <b>HLD</b>
	SW Custom	CH-6 <b>HLD</b>
	Failsafe	CH-7 <b>HLD</b>
	Servo SPD <b>50</b>	CH-8 <b>HLD</b>
	Telemetry	
	RGB	
	TX Type	

Functional specifications

Failsafe support <HOLD>, <STOP> and <Value Custom>

- <HOLD>: receiver will keep the last PWM output when signal lost, usually used for normal SW channels, like car door and light control.
- <STOP>: receiver will stop PWM output (no PWM output) when signal lost, the failsafe will "pushed down" to the device connect to this channel. Usually used for ESC, **please read ESC manual carefully to ensure safe operation.**
- <Value Custom>: receiver will output custom PWM value when signal lost, for expert use only.

Notice:

- Use reasonable failsafe setting **under the premise of ensuring safety**, remove motor gear then power off transmitter to test failsafe working properly or not.
- After setting failsafe and servo speed on the transmitter, receiver perform user setting not more than 20 seconds.
- All the channels of receiver will keep 50Hz PWM output after power on, receiver perform the failsafe and servo speed setting not more than 20 seconds after receiving signals.

■ Telemetry voltage and receiver connect / lost alert setting.

Setting <b>M0</b>	Model Setting <b>M0</b>	Telemetry <b>M0</b>	Functional specifications
Exit	Exit	Exit	
切换到中文	Model No. <b>0</b>	C / L Alert <b>ON</b>	Buzz & vibration when receiver connect or lost
Model	Model Name	LV Alert <b>OFF</b>	Buzz & vibration when telemetry voltage below <LV setting>
Advanced	ST Setting	LV setting <b>74</b>	Telemetry low voltage alert value
About	TH Setting	Offset <b>0</b>	Adjust the telemetry voltage between real battery voltage
	CH Remap		
	SW Custom		
	Failsafe		
	Servo SPD <b>50</b>		
	Telemetry		
	RGB		
	TX Type		

Notice: <LV setting> value is the total voltage of serial battery, transmitter don't know how many cells in serial battery, also don't know battery type. User need set the telemetry low voltage alert value depend on actual situation.

In main menu Battery icon  meaning LV Alert OFF, icon  meaning LV Alert ON.

■ Bind function in transmitter menu.

Setting	MS	Advanced	MS
Exit		Exit	
切换到中文		Bind TLM-On	
Model		Bind TLM-Off	
Advanced		LCD-BRT	
About		LCD-Contrast	
		SW-Color	
		SW-BRT	
		Calibration	
		Reset	



■ Power on the receiver then press the <BIND> key within 10 second until **green blue** LED fast blink meaning receiver in bind mode. Select the <Bind TLM-On> or <Bind TLM-Off> option on the transmitter <Setting>, <Advanced> menu, respectively to the receiver's <TELEMETRY ON> or <TELEMETRY OFF> mode. Receiver will **red blue** slow blink or **red green** slow blink after bind success. User need exit transmitter from bind menu and cycle receiver power. The LED meaning please refer to receiver manual.

■ <Bind TLM-On> & <TELEMETRY ON> mode : Bidirectional communication between transmitter and receiver, receiver will send telemetry packet to transmitter, user can set the alert voltage value on the transmitter. One model file on the transmitter can bind more than one <TELEMETRY ON> mode receiver, **but user need keep ONLY ONE receiver power on at the same time**, because more than one <TELEMETRY ON> mode receiver working in parallel will results in telemetry packet error.

■ <Bind TLM-Off> & <TELEMETRY OFF> mode : One-way communication between transmitter and receiver, user can't view the telemetry data and signal strength on transmitter.

Notice:

■ The CT series transmitter use LDARC O<sub>2</sub> wireless system, each model file of transmitter have unique ID. This feature lets receiver bind to model file instead of transmitter. **if receiver does not bind to current running model file will go to failsafe mode, even when use the same transmitter.**

Electrical performance

- Operating voltage : 3.5V ~ 4.2V
- Operating current : less than 90mA (all light off)
- Operating current : less than 300mA (all light maximum brightness)
- Charging current : 600mA
- Weight : 240g (not include battery)

LDARC O<sub>2</sub> wireless system

- Wireless packet refresh time : 7.5ms
- Communication data rate : 1Mbps
- Channel resolution : 11bit (2048)
- PWM maximum range : 900us ~ 1500us ~ 2100us (±125%)
- Total channels of O<sub>2</sub> system : 16 channels (CT01 only use CH1~8)

8 channels hardware define

- 2 linear channels : ST and TH
- 3 channels with 3 gears : SWA、SWB、SWC
- 1 channel with 2 gears : SWD
- 1 trigger channel : SWE
- 1 virtual potentiometer channel : SV1

LDARC O<sub>2</sub> wireless system supports

- LDARC CT series transmitter
- LDARC CR series receiver
- LDARC X43 micro off-roader
- LDARC M58 micro monster truck

[WWW.LDARC.COM](http://WWW.LDARC.COM)