

RPLIDAR A3

Low Cost 360 Degree Laser Range Scanner

Introduction and Datasheet

Model: A3M1

OPTMA

16K

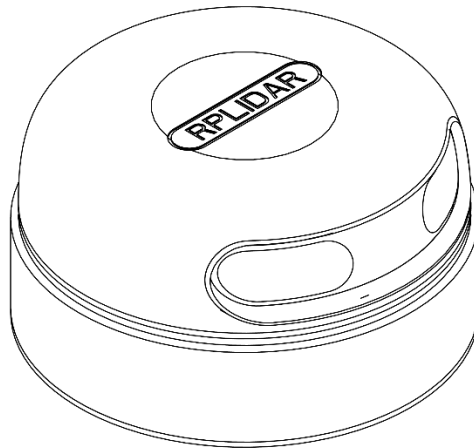

CONTENTS	1
INTRODUCTION	3
SYSTEM CONNECTION	4
MECHANISM.....	5
SAFETY AND SCOPE	6
DATA OUTPUT.....	6
HIGH SPEED SAMPLING PROTOCOL AND COMPATIBILITY	7
APPLICATION SCENARIOS.....	8
SPECIFICATION	9
MEASUREMENT PERFORMANCE	9
LASER POWER SPECIFICATION.....	9
OPTICAL WINDOW.....	10
COORDINATE SYSTEM DEFINITION OF SCANNING DATA	10
COMMUNICATION INTERFACE	11
MISC.....	14
SELF-PROTECTION AND STATUS DETECTION	15
SDK AND SUPPORT	16
MECHANICAL DIMENSIONS	17
REVISION HISTORY	18
APPENDIX	19
IMAGE AND TABLE INDEX	19



The RPLIDAR A3M1 is the next generation low cost 360 degree 2D laser scanner (LIDAR) solution developed by SLAMTEC. It can take up to 16000 samples of laser ranging per second with high rotation speed. And equipped with SLAMTEC patented OPTMAG technology, it breakouts the life limitation of traditional LIDAR system so as to work stably for a long time.

The system can perform 2D 360-degree scan within a 25-meter range. The generated 2D point cloud data can be used in mapping, localization and object/environment modeling.

Compared with RPLIDARs in other series, RPLIDAR A3M1 has a more stable performance when detecting objects in long distance, objects in white or black alternatively and objects under direct sunlight, which is ideal for map building in the outdoor environment within a 25-meter ranging radius. Therefore, it can be widely applied in many consumer-oriented business scenarios. RPLIDAR A3M1 supports to work under two modes alternatively: enhanced mode and outdoor mode. In the enhanced mode, it works with the maximum ranging radius and sampling rate to realize an optimistic mapping performance in the indoor environments. While in the outdoor mode, RPLIDAR A3M1 works with a more reliable resistance to daylight interference, which prevents it from “blind” in outdoor environment.

The typical scanning frequency of RPLIDAR A3M1 is 10Hz(600rpm), and the frequency can be freely adjusted within the 5-15Hz range according to the specific

requirements. With the 10Hz scanning frequency, the sampling rate is 16kHz and the angular resolution is 0.225° .

Due to the improvements in SLAMTEC hardware operating performance and related algorithm, RPLIDAR A3M1 works well in all kinds of indoor environment and outdoor environment with direct sunlight. Meanwhile, before leaving the factory, every RPLIDAR A3M1 has passed the strict testing to ensure the laser output power meet the eye-safety standard of IEC-60825 Class 1.

System connection

The RPLIDAR A3M1 consists of a range scanner core and the mechanical powering part which makes the core rotate at a high speed. When it functions normally, the scanner will rotate and scan clockwise. And users can get the range scan data via the communication interface of the RPLIDAR and control the start, stop and rotating speed of the rotate motor via PWM.

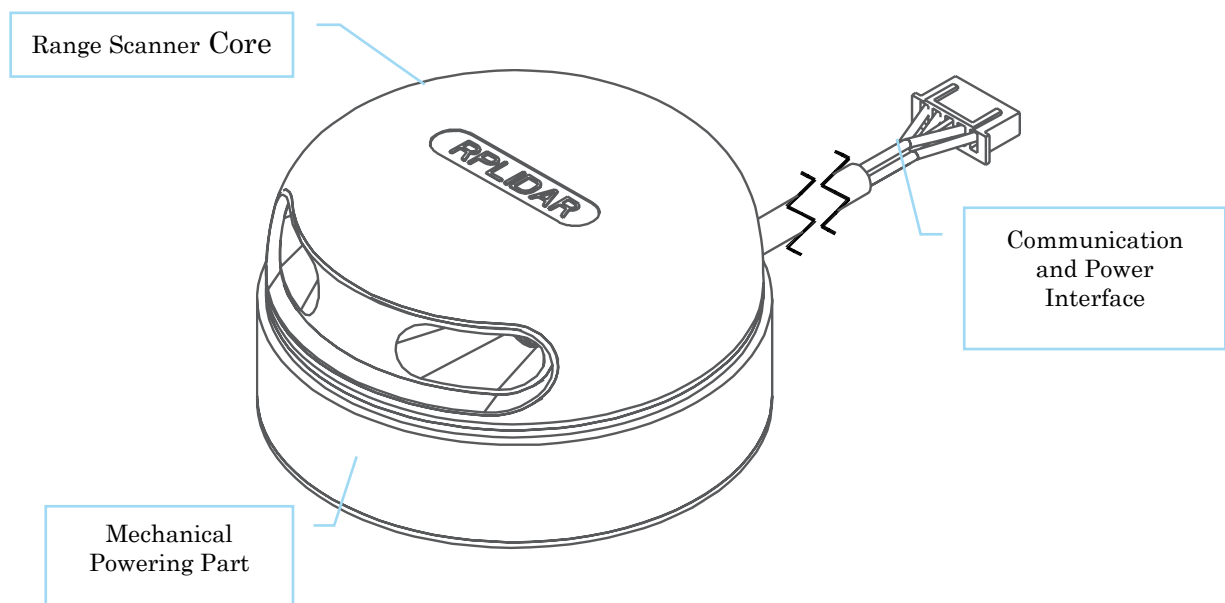

Figure 1-1 RPLIDAR System Composition

The RPLIDAR A3M1 comes with a rotation speed detection and adaptive system. The system will adjust the angular resolution automatically according to the actual rotating speed. And there is no need to provide complicated power system for RPLIDAR. In this way, the simple power supply schema saves the BOM cost. If the actual speed of the RPLIDAR is required, the host system can get the related data via communication interface.

The detailed specification about power and communication interface can be found in the following sections.

Mechanism

The RPLIDAR A3M1 is based on laser triangulation ranging principle and adopts the high-speed vision acquisition and processing hardware developed by SLAMTEC. The system ranges more than 16000 times per second.

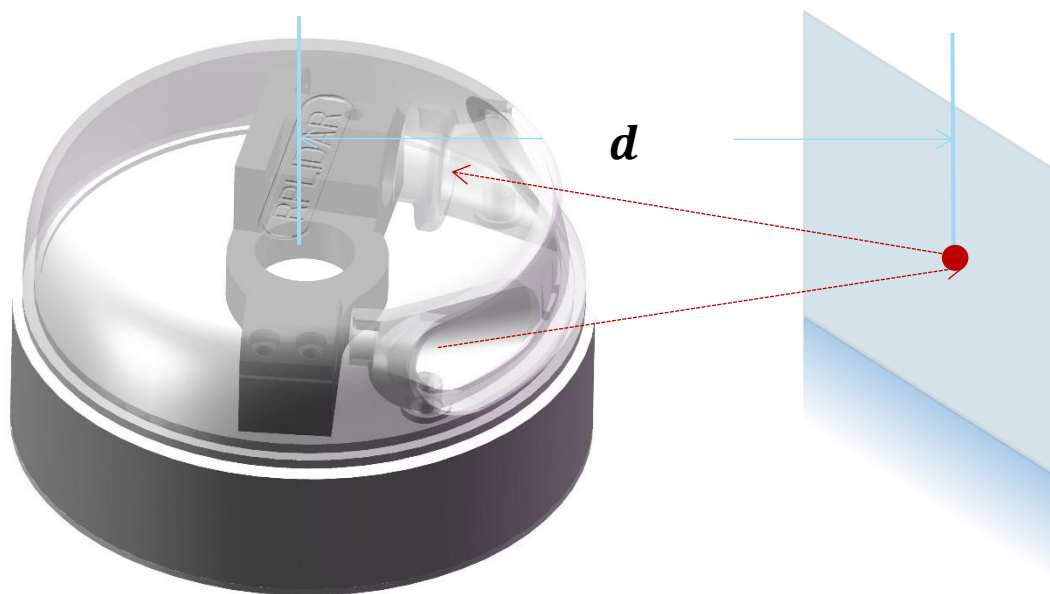
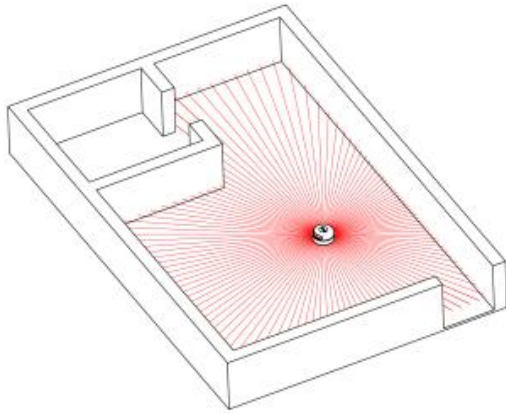

Figure 1-2 The RPLIDAR Working Schematic

During every ranging process, the RPLIDAR emits modulated infrared laser signal and the laser signal is then reflected by the object to be detected. The returning signal is then sampled by vision acquisition system in RPLIDAR and the DSP embedded in RPLIDAR starts processing the sample data and outputs distance value and angle value between object and RPLIDAR via communication interface.

When drove by the motor system, the range scanner core will rotate clockwise and perform the 360-degree scan for the current environment.



*Note : The LIDAR scan image is not directly relative to the environment showed here. Illustrative purpose only.

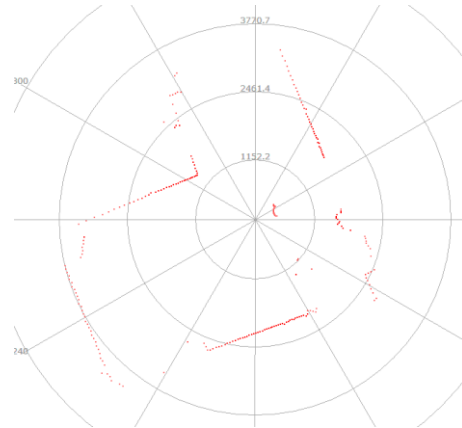

Figure 1-3 The Obtained Environment Map from RPLIDAR Scanning

Safety and Scope



Class I

The RPLIDAR A3M1 system uses a low power infrared laser as its light source, and drives it by using modulated pulse. The laser emits light in a very short time frame which can ensure its safety to human and pet, and it reaches Class I laser safety standard. Complies with 21 CFR 1040.10 and 1040.11 except for deviations pursuant to Laser Notice No. 50, dated June 24, 2007.

Caution: Use of controls or adjustments or performance of procedures other than those specified herein may result in hazardous radiation exposure.

The modulated laser can effectively avoid the interference from ambient light and sunlight during ranging scanning process, which makes RPLIDAR work excellent in all kinds of indoor environment and outdoor environment without sunlight.

Data Output

During the working process, the RPLIDAR will output the sampling data via the communication interface. And each sample point data contains the information in

the following table. If you need detailed data format and communication protocol, please contact SLAMTEC.

Data Type	Unit	Description
Distance	mm	Current measured distance value between the rotating core of the RPLIDAR and the sampling point
Heading	degree	Current heading angle of the measurement
Start Flag	(Bool)	Flag of a new scan
Checksum		The Checksum of RPLIDAR return data

Figure 1-4 The RPLIDAR Sample Point Data Information

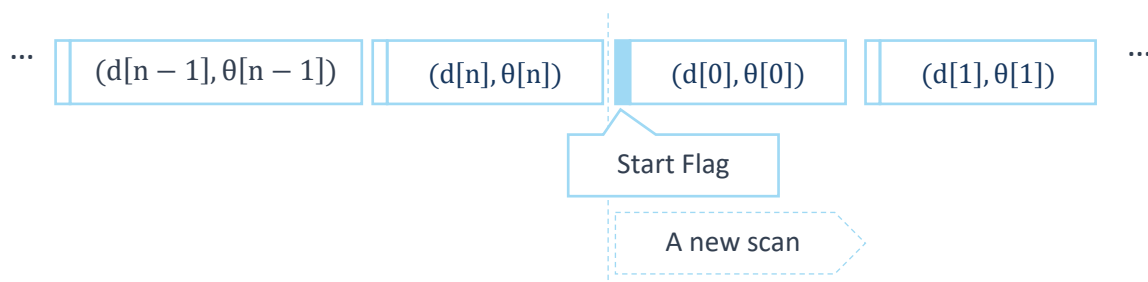

Figure 1-5 The RPLIDAR Sample Point Data Frames

The RPLIDAR outputs sampling data continuously and it contains the sample point data frames in the above figure. Host systems can configure output format and stop RPLIDAR by sending stop command. For detailed operations please contact SLAMTEC.

High Speed Sampling Protocol and Compatibility

The RPLIDAR A3M1 adopts the newly extended high speed sampling protocol for outputting the 16000 times per second laser range scan data. Users are required to update the matched SDK or modify the original driver and use the new protocol for the 16000 times per second mode of RPLIDAR A3M1. Please check the related protocol documents for details.

Application Scenarios

The RPLIDAR can be used in the following application scenarios:

General robot navigation and localization

Environment scanning and 3D re-modeling

Service robot or industrial robot working for long hours

Home service /cleaning robot navigation and localization

General simultaneous localization and mapping (SLAM)

Smart toy's localization and obstacle avoidance

Measurement Performance

- For Model A3M1 Only

Item	Enhanced Mode	Outdoor Mode
Application Scenarios	Extreme performance Ideal for indoor environments with maximum ranging distance and sampling frequency.	Extreme reliability Ideal for both outdoor and indoor environments with reliable resistance to daylight.
Operating Range	White object: 25 meters	White object: 20 meters
	Black object: 10 meters	Black object: TBD
Minimum Operating ranging	0.2m	0.2m
Sample Rate	16 kHz	16 kHz or 10 kHz
Scan Rate	Typical value: 10 Hz (adjustable between 5 Hz-15 Hz)	
Angular Resolution	0.225°	0.225° or 0.36°
Scan Field Flatness	±1.5	
Communication Interface	TTL UART	
Communication Speed	256000 bps	
Compatibility	Support former SDK protocols	

Figure 2-1 RPLIDAR Performance

Note: the triangulation range system resolution changes along with distance.

Laser Power Specification

- For Model A3M1 Only

Item	Unit	Min	Typical	Max	Comments
Laser wavelength	Nanometer(nm)	775	785	795	Infrared Light Band
Laser power	Milliwatt (mW)	-	10	12	Peak power
Pulse length	Microsecond(us)	60	87	90	-
Laser Safety Class	-	-	IEC-60825 Class 1	-	-

Figure 2-2 RPLIDAR Optical Specification

Note: the laser power listed above is the peak power and the actual average power is much lower than the value.

Optical Window

To make the RPLIDAR A3M1 working normally, please ensure proper space to be left for its emitting and receiving laser lights when designing the host system. The obscuring of the host system for the ranging window will impact the performance and resolution of RPLIDAR A3M1.

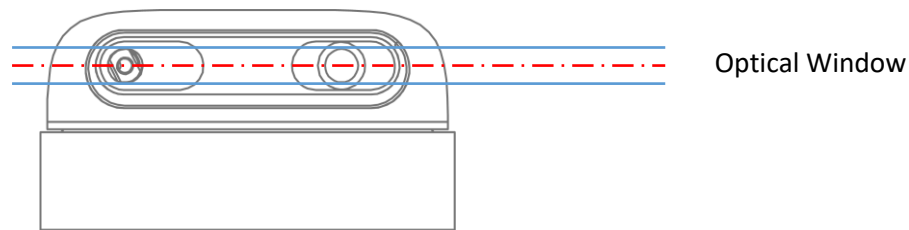

Figure 2-3 RPLIDAR Optical Window

You can check the Mechanical Dimensions chapter for detailed window dimensions.

Coordinate System Definition of Scanning Data

The RPLIDAR A3M1 adopts coordinate system of the left hand. The dead ahead of the sensors is the x axis of the coordinate system; the origin is the rotating center of the range scanner core. The rotation angle increases as rotating clockwise. The detailed definition is shown in the following figure:

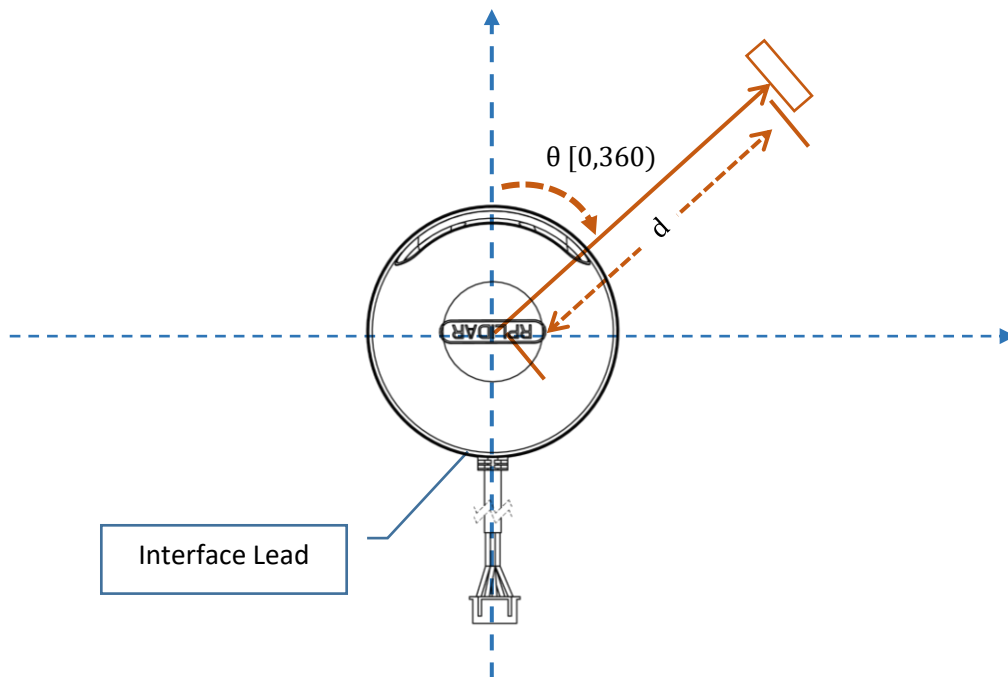

Figure 2-4 RPLIDAR Scanning Data Coordinate System Definition

Communication interface

The RPLIDAR A3M1 uses separate 5V DC power for powering the range scanner core and the motor system. And the standard RPLIDAR A3M1 uses XH2.54-5P male socket. Detailed interface definition is shown in the following figure:

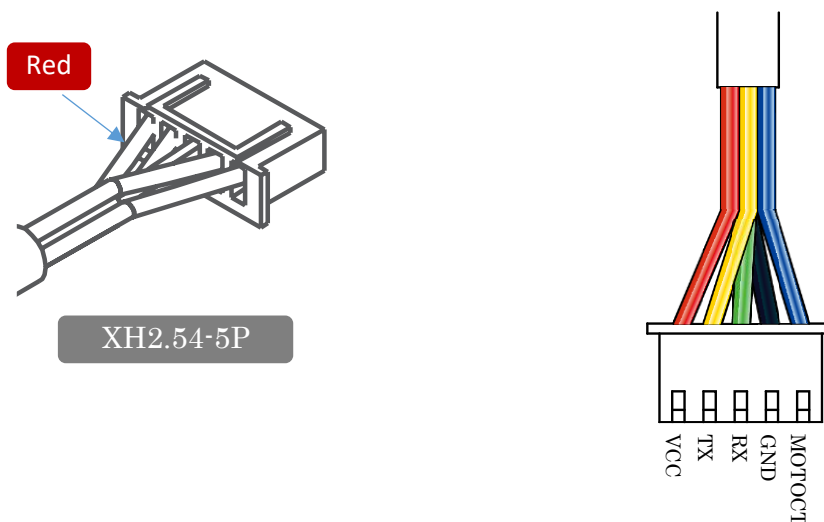

Figure 2-5 RPLIDAR Power Interface Definition

Color	Signal Name	Type	Description	Min	Typical	Max
Red	VCC	Power	Total Power	4.9V	5V	5.2V
Yellow	TX	Output	Serial port output of the scanner core	0V	3.3V	3.5V
Green	RX	Input	Serial port input of the scanner core	0V	3.3V	3.5V
Black	GND	Power	GND	0V	0V	0V
Blue	MOTOCTL	Input	Scan motor /PWM Control Signal (active high, internal pull down)	0V	3.3V	5V

Figure 2-6 RPLIDAR External Interface Signal Definition

Power Supply Interface

RPLIDAR A3M1 takes the only external power to power the range scanner core and the motor system which make the core rotate. To make the RPLIDAR A3M1 work normally, the host system needs to ensure the output of the power and meet its requirements of the power supply ripple.

● For Model A3M1 Only

Item	Unit	Min	Typical	Max	Remark
Power Voltage	V	4.9	5	5.2	If the voltage exceeds the max value, it may damage the core
Power Ripple	Voltage mV	-	20	50	High ripple may cause the core working failure.
Inrush Current	mA			2500*	
System Current	Start mA	-	-	1500	The system startup requires relatively higher current.
Power Current	mA	TBD	200	220	5V Power, power off
		TBD	450	600	5V Power, power on

Figure 2-7 RPLIDAR Power Supply Specification

Note: When the lidar is connected to the power supply, there is a process of charging the input capacitor. The maximum transient current of charging can

reach 2500mA. After stable operation, the working current does not exceed 600mA.

Data communication interface

The RPLIDAR A3M1 takes the 3.3V-TTL serial port (UART) as the communication interface. The table below shows the transmission speed and the protocol standard.

Item	Unit	Min	Typical	Max	Comments
Band rate	bps	-	256000	-	-
Working mode	-	-	8N1	-	8n1
Output high voltage	Volt (V)	2.9	-	3.5	Logic High
Output low voltage	Volt (V)	-	-	0.4	Logic Low
Input high voltage	Volt (V)	1.6*	-	3.5	Logic High
Input low voltage	Volt (V)	-0.3	-	0.4	Logic Low

Figure 2-8 RPLIDAR Serial Port Interface Specifications

Note: the RX input signal of A3M1 is current control type. In order to ensure the reliable signal identification inside the system, the actual control node voltage of this pin will not be lower than 1.6v.

Scanner Motor Control

The RPLIDAR A3M1 is embedded with a motor driver which has speed tuning feature. Users can control the start, the stop and the rotating speed for the motor via MOTOCTL in the interface. MOTOCTL can be supplied using PWM signal with special frequency and duty cycle, and in this mode, the rotating speed is decided by the duty cycle of the input MOTOCTL PWM Signal.

The following table describes the requirement for the input PWM signal of MOTOCTL:

Item	Unit	Min	Typical	Max	Comments
------	------	-----	---------	-----	----------

High voltage level	V	3.0V	3.3V	5V	-
PWM frequency	Hz	24,500	25,000	25,500	Square Signal
Duty cycle range	-	0%	60%*	100%	Typical value is the duty cycle of high pulse width when the scanner frequency is at 10Hz

Figure 2-9 RPLIDA Specification for PWM Signal of MOTOCTL

Note: the typical value is tested when the scanner rotating frequency is 10Hz. With the same rotating speed, the PWM duty cycle of every RILIDAR A3M1 may vary slightly. If a precise rotating speed is required, users can perform a closed-loop control.

If the host system only need to control the start and stop of the motor, please use the direct current signal in high level and low level to drive MOTOCTL. Under this condition, when the MOTOCTL is the low level signal, the RPLIDAR A3M1 will stop rotating and scanning; when the MOTOCTL is the high level signal, the RPLIDAR A3M1 will rotated at the highest speed.

MISC

● For Model A3M1 Only

Item	Unit	Min	Typical	Max	Comments
Weight	Gram (g)	TBD	190	TBD	
Temperature range	Degree Celsius (°C)	0	20	40	

Figure 2-10 RPLIDAR MISC Specification

To ensure the laser of RPLIDAR always working in the safety range (<3mW) and avoid any other damage caused by device, the RPLIDAR comes with laser power detection and sensor healthy check feature. It will shut down the laser and stop working automatically when any of the following errors has been detected.

Laser transmit power exceeds limited value

Laser cannot power on normally

Scan speed of Laser scanner system is unstable

Scan speed of Laser scanner system is too slow

Laser signal sensor works abnormally

The host systems can check the status of the RPLIDAR via the communication interface and restart the RPLIDAR to try to recover work from error.

To facilitate the usage of RPLIDAR A3 in the product development and speed up the development cycle for users, SLAMTEC has provided the **Framegrabber** plugin in RoboStudio for testing and debugging as well as the SDK available under Windows, x86 Linux and Arm Linux. Please contact SLAMTEC for detail information.

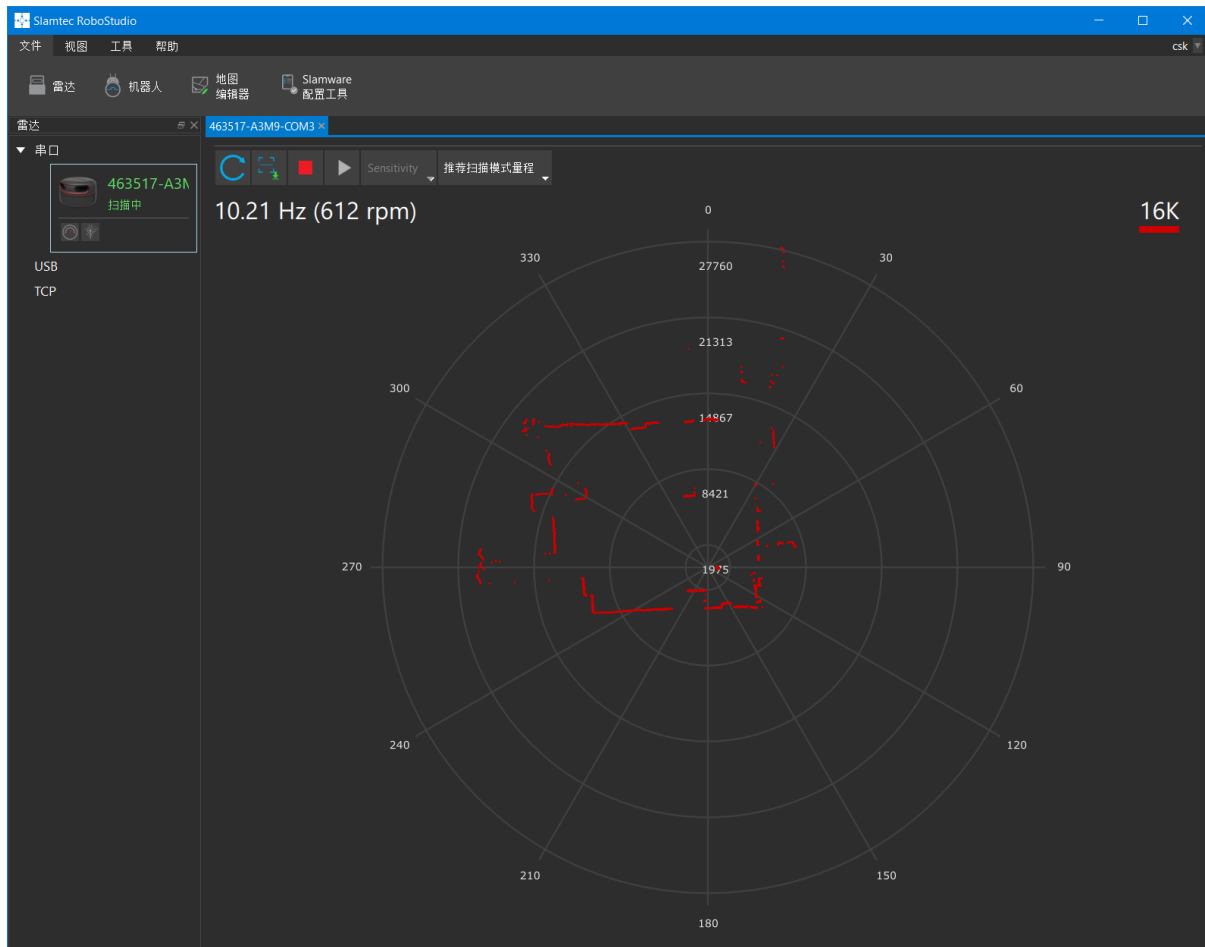

Figure 4-1 the Framegrabber Plugin in RoboStudio

The mechanical dimensions of the RPLIDAR A3M1 are shown as below:

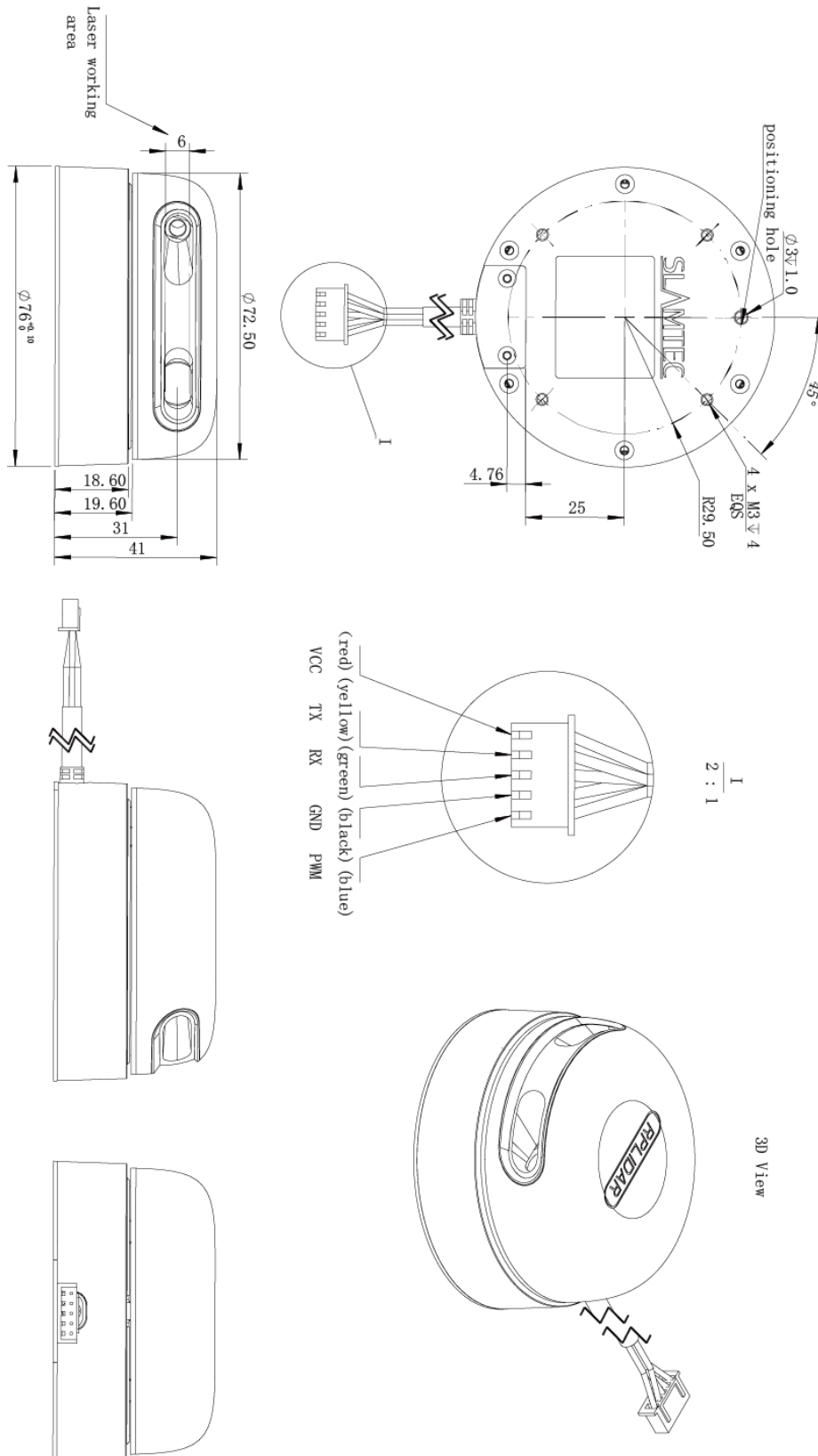

Figure 5-1 RPLIDAR Mechanical Dimensions

Note: the 4 M3 screws in the bottom should be no longer than 4mm, or the internal module would be damaged.

Date	Version	Description
2018-01-24	1.0	Initial version for A3M1
2018-09-15	1.1	Modify measurement distance of outdoor mode
2018-09-26	1.2	Add product laser safety instructions and warnings, and last page product production instructions.
2019-02-14	1.3	Added a description of scan field flatness in Figure 2-1. The maximum value of system startup current in table 2-7 is changed to 2500 mA.
2019-03-21	1.4	The maximum value of system startup current in table 2-7 is changed to 1500 mA. Adds the maximum inrush current of 2500 mA in table 2-7.
2019-05-08	1.5	Added a description of Minimum Operating ranging in Figure 2-1.
2019-10-25	1.6	The maximum working environment temperature is modified to 40 in Figure 2-10.
2019-10-25	1.7	The typical scanning frequency is changed to 10Hz, and the maximum value is changed to 15Hz in Figure 2-1.
2020-11-17	1.8	Corrected 5~20Hz in P2 to 5~15Hz
2021-04-02	1.9	(1) Modify the maximum VCC voltage of 5.5V to 5.2V in Figure 2-6. (2) Modify the maximum power supply voltage 5.5V to 5.2V in Figure 2-7.
2026-03-12	1.10	Update "Optical Window"

Image and Table Index

FIGURE 1-1 RPLIDAR SYSTEM COMPOSITION	4
FIGURE 1-2 THE RPLIDAR WORKING SCHEMATIC.....	5
FIGURE 1-3 THE OBTAINED ENVIRONMENT MAP FROM RPLIDAR SCANNING.....	6
FIGURE 1-4 THE RPLIDAR SAMPLE POINT DATA INFORMATION	7
FIGURE 1-5 THE RPLIDAR SAMPLE POINT DATA FRAMES.....	7
FIGURE 2-1 RPLIDAR PERFORMANCE	9
FIGURE 2-2 RPLIDAR OPTICAL SPECIFICATION.....	9
FIGURE 2-3 RPLIDAR OPTICAL WINDOW.....	10
FIGURE 2-4 RPLIDAR SCANNING DATA COORDINATE SYSTEM DEFINITION.....	11
FIGURE 2-5 RPLIDAR POWER INTERFACE DEFINITION.....	11
FIGURE 2-6 RPLIDAR EXTERNAL INTERFACE SIGNAL DEFINITION	12
FIGURE 2-7 RPLIDAR POWER SUPPLY SPECIFICATION.....	12
FIGURE 2-8 RPLIDAR SERIAL PORT INTERFACE SPECIFICATIONS	13
FIGURE 2-9 RPLIDA SPECIFICATION FOR PWM SIGNAL OF MOTOCTL.....	14
FIGURE 2-10 RPLIDAR MISC SPECIFICATION	14
FIGURE 4-1 THE LIDARS PLUGIN IN ROBOSTUDIO.....	16
FIGURE 5-1 RPLIDAR MECHANICAL DIMENSIONS.....	17

Manufacturer: SHANGHAI SLAMTEC CO., LTD.

Address: Room 601, 6th Floor, Kailong Technology Building, Building 3, No. 6, Lane 3158,
Longdong Avenue, Pudong New District, Shanghai

Made in China